

**THE BOARD OF SUPERVISORS OF THE COUNTY OF STANISLAUS
BOARD ACTION SUMMARY**

DEPT: General Services Agency

BOARD AGENDA:6.B.5
AGENDA DATE: January 9, 2018

SUBJECT:

Approval of an Agreement with Elevator Industries, Inc. for Elevator Modernization at the Men's Jail

BOARD ACTION AS FOLLOWS:

RESOLUTION NO. 2018-0030

On motion of Supervisor Chiesa , Seconded by Supervisor Withrow
and approved by the following vote,

Ayes: Supervisors: Olsen, Chiesa, Withrow, Monteith, and Chairman DeMartini

Noes: Supervisors: None

Excused or Absent: Supervisors: None

Abstaining: Supervisor: None

1) Approved as recommended

2) Denied

3) Approved as amended

4) Other:

MOTION:

ATTEST: 
PAM VILLARREAL, Assistant Clerk

File No.

**THE BOARD OF SUPERVISORS OF THE COUNTY OF STANISLAUS
AGENDA ITEM**

DEPT: General Services Agency

BOARD AGENDA:6.B.5
AGENDA DATE: January 9, 2018

CEO CONCURRENCE: YES

4/5 Vote Required: No

SUBJECT:

Approval of an Agreement with Elevator Industries, Inc. for Elevator Modernization at the Men's Jail

STAFF RECOMMENDATION:

1. Approve an agreement with Elevator Industries, Inc. for the bid amount of \$111,141, plus a 5% contingency, for a total not to exceed amount of \$116,698 for elevator modernization at the Men's Jail located at 1115 H Street in Modesto.
2. Authorize the Purchasing Agent to execute the contract with Elevator Industries, Inc., sign any necessary documents, and execute any subsequent amendments on behalf of the County.

DISCUSSION:

The Men's Jail, located at 1115 H Street in Modesto, was built in 1957 with three aboveground floors and one basement floor. The building is served by a single traction-type passenger elevator manufactured by Montgomery, which is original to the building. This elevator has required non-routine repairs and modifications with increasing frequency over the years, and is in need of modernization due to age and wear.

Elevator modernization is a time and cost-effective repair process that upgrades critical components with newer technology to improve both safety and performance. These critical components typically include the controller equipment, hoist machines and motors, electrical wiring and buttons, and doors.

The General Services Agency Purchasing Division (GSA) posted Request for Bids (Bid) No. 17-22-BD for Elevator Modernization at the Men's Jail on March 6, 2017, which set forth the scope of work. The Bid notice was sent to 179 companies, and 30 downloaded the Bid documents. Two contractors attended the non-mandatory pre-bid meeting held on-site March 22, 2017.

When the Bid closed April 19, 2017, GSA had received responses from two contractors, listed below:

Company Name	Total Bid
Elevator Industries, Inc. (Sacramento, CA)	\$111,141
Elevator Technology, Inc. (El Dorado Hills, CA)	\$141,218

Elevator Industries, Inc. is the lowest-priced responsive and responsible bidder. On April 24, 2017, GSA issued a Notice of Intent to Award to Elevator Industries, Inc., posted such notice online at PublicPurchase.com, and issued a Notice of Non-Award to the other bidder. No letters of protest were received during the five-day protest period of the bid process.

If approved, the agreement will be effective upon the issuance of a Notice-to-Proceed letter (Notice). Page 30 of the Bid documents allows forty-five working days for project completion from the date of the Notice.

Normal operating hours for the Men's Jail building are 24 hours per day, 7 days a week. While a shutdown of County operations is not planned, the elevator itself will be unusable during the retrofit period, and personnel must use the stairs while the work is being completed. The majority of the Men's Jail population will be transferred to the Public Safety Center before the elevator retrofit work begins, with the final move-out scheduled for February 2019. The Men's Jail building will then be utilized as a court holding facility, so the elevator retrofit work needs to be completed for continued safe operation of the elevator.

POLICY ISSUE:

The County's purchasing policy requires Board of Supervisors approval for contracts exceeding \$100,000. This requirement is based upon California Government Codes § 25212, et seq, and § 25502.5, et seq, which establish the powers of the Board of Supervisors and the Purchasing Agent.

FISCAL IMPACT:

The proposed contract shall cover modernization of one elevator at the Men's Jail for the bid amount of \$111,141, plus a 5% contingency, for a total not to exceed amount of \$116,698. Funding is included in the Chief Executive Office Plant Acquisition, Deferred Maintenance Fiscal Year 2017-2018 Adopted Final Budget.

BOARD OF SUPERVISORS' PRIORITY:

Approval of this item supports the Board of Supervisors' priority of *Delivering Efficient Public Services and Infrastructure* by providing cost-effective elevator repair for the affected County departments.

STAFFING IMPACT:

Existing GSA staff will manage the contract for the elevator modernization services.

CONTACT PERSON:

Keith D. Boggs, GSA Director/Purchasing Agent
Brad Diemer, Purchasing Manager

Telephone: (209) 525-7640
Telephone: (209) 525-6319

ATTACHMENT(S):

1. Elevator Industries, Inc. Agreement

AGREEMENT
(for Public Works of Improvement)

This Agreement, made this January 9, 2018, by and between ELEVATOR INDUSTRIES INC. ("Contractor") and the COUNTY OF STANISLAUS ("County").

ARTICLE I

The Contractor will provide all the materials, tools, equipment and labor and perform all the work necessary to complete in a good workmanlike manner:

BID NAME: ELEVATOR MODERNIZATION AT MEN'S JAIL
BID NO.: 17-22-BD

as set forth in the Bid of the Contractor and in accordance with the Bid, Notice to Bidders, Information for Bidders, General Conditions, plans and specifications, bonds, addenda, Exhibit A to this Agreement and any documents particularly required or provided, all of which are attached hereto and made a part hereof. All of the foregoing documents, together with this Agreement, comprise the contract.

ARTICLE II

All of the Work included in this contract is to be performed under the direction of the County, and in conformity with the true construction and meaning of the contract, as determined solely by the County.

ARTICLE III

No alterations in the Work shall be made except upon a written change order issued by the Stanislaus County Purchasing Agent. The amount to be paid by the County or to be deducted from the contract price by virtue of such alterations shall be detailed and stated in said change order and shall be approved in writing by the County and the Contractor.

Changes, additions, and alterations in the Work, may be ordered in writing by the Purchasing Agent of the County of Stanislaus in the form of a written change order.

ARTICLE IV

The Contractor shall commence the Work within **ten (10) working days** after the date specified in the Notice to Proceed given to it by the Purchasing Agent shall prosecute said Work in a prompt, diligent and workmanlike manner. The Contractor shall complete the Work within **forty-five (45) working days** unless extension or suspension of the Work is agreed to in writing by the County. Time is of the essence in this Agreement.

ARTICLE V

County shall pay to Contractor in due course and at the usual time for payment of County obligations after the last day of each month, ninety-five percent (95%) of the cost of the Work completed and material properly stored on the job site, which cost shall be determined by the County. A final payment of five percent (5%) of the contract price shall be due the Contractor 35 days after acceptance of the Work, provided that the Contractor furnishes to the County satisfactory evidence that all obligations for labor and materials have been satisfactorily fulfilled within the said 35 day period, and further provided that no payment shall be construed to be an acceptance of defective work or improper materials.

Except as otherwise prohibited by law, Contractor may elect to receive all payments due under the contract without any retention. If Contractor so elects, it shall deposit with County securities with a value equal to the

monies, which would otherwise be withheld by the County. Said securities shall be as provided in Section 22300 of the Public Contract Code and shall be approved by County as to both sufficiency and form.

ARTICLE VI

Prior to commencing the Work, the Contractor shall file a bond issued by a surety company, approved by the County, and in the form acceptable to the County in the amount of one hundred percent (100%) of the contract price for the faithful payment and satisfaction of all lawful claims of all persons for labor and materials furnished in the prosecution of the contract Work. Prior to commencing the Work, the Contractor shall file a bond issued by a surety company, approved by the County, and in the form acceptable to the County in the amount of one hundred percent (100%) of the contract price to guarantee the faithful performance of the contract.

ARTICLE VII

The Contractor shall take out and maintain during the life of the contract the insurance required and listed in the General Conditions, Section 2.14, of the contract documents.

ARTICLE VIII

When the Work is completed and ready for final inspection, the Contractor shall notify the County which shall make such final inspection within five (5) days after notice.

If the County shall approve the Work and find that the Work is complete and ready for acceptance and shall accept the same, the final payment of the contract price shall be due as provided in Article V, hereof.

ARTICLE IX

Contractor shall comply with all the provisions of state and local laws relating to contracts for the prosecution of public works. Pursuant to law, the County has ascertained the general prevailing rate of per diem wages in the locality of the work for each craft or type of workman required for performance of the contract, which rates are as stated in the Invitation to Bidders, and the Contractor shall be required to pay not less than said prevailing rates. Contractor is required to post a copy of these prevailing wage rates at the job site.

ARTICLE X

Whenever any act is directed to be done or notice directed to be given by or to the County hereof, the same may be done or given by or to the Purchasing Agent.

ARTICLE XI

The Contractor shall not assign the contract or sublet it as a whole without the written consent of the County, nor shall the Contractor assign any monies due or to become due to him hereunder without the previous written consent of the County. Contractor shall comply with the Subcontractor Listing Law. This contract shall be binding upon the parties hereto, their heirs, successors, assigns, subcontractors, and legal representatives.

ARTICLE XII

Any alteration or alterations made in this contract, or any part hereof, shall not operate to release any surety from liability of any bond given pursuant to the provisions of this contract and the consent of such surety to such alteration or alterations is hereby given, the surety expressly waiving hereby the provisions of Section 2819 of the Civil Code.

ARTICLE XIII

Neither the final certificate nor payment, nor any provision of the related documents, shall relieve the Contractor of responsibility for faulty workmanship or materials, and less otherwise specified, he shall remedy any defects

due thereto and pay for any damage to other work resulting therefrom which shall appear within a period of one (1) year from the date of filing Notice of Completion. The County shall give notice of observed defects with reasonable promptness. All questions arising under this Article shall be decided by the Purchasing Agent.

COUNTY OF STANISLAUS

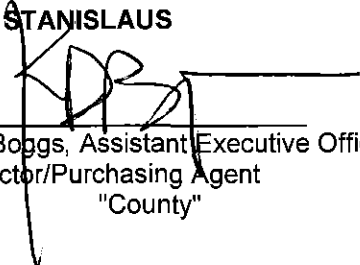
By: 
Keith D. Boggs, Assistant Executive Officer,
GSA Director/Purchasing Agent
"County"

ELEVATOR INDUSTRIES INC.

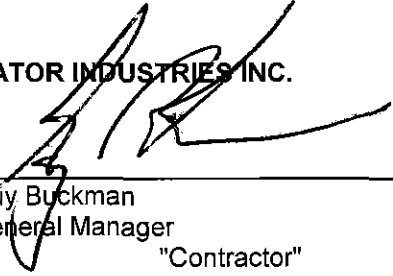
By: 
Guy Buckman
General Manager
"Contractor"

APPROVED AS TO CONTENT:
GSA Department, Facilities Maintenance Division

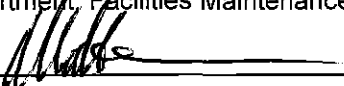
By: 
Matt Innes
Facilities Maintenance Manager

APPROVED AS TO FORM:

John P. Doering
County Counsel

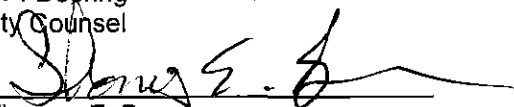
By: 
Thomas E. Boze
Assistant County Counsel

GENERAL CONDITIONS.

2.01 OWNER. The term "Owner", where used herein, shall mean the County of Stanislaus, a political subdivision of the State of California.

2.02 BOARD. The term "Board", where used herein, shall mean the Stanislaus County General Services Agency of the County of Stanislaus, California.

2.03 ENGINEER. The Stanislaus County General Services Agency Facilities Maintenance Manager shall supervise and be responsible for the Work, and whenever the word "Director" or the word "Engineer" is used herein, it shall mean the Facilities Maintenance Manager of the County of Stanislaus, acting either directly or through properly authorized agents, such agents acting within the scope of the particular duties delegated to them.

2.04 CONTRACTOR. The term "Contractor", where used herein, shall mean the Contractor to whom the contract for the Work described and specified herein has been awarded to by the Board.

2.05 SUBCONTRACTOR. The term "Subcontractor", where used herein, includes only those having a direct contract with the Contractor for the Work or portion of the Work described and specified herein.

2.06 WORK. The term "Work", where used herein, includes all labor, materials and any necessary equipment required for complete performance of the contract.

2.07 CONTRACT DOCUMENTS. The term "Contract Documents", where used herein, includes the following: The Notice to Bidders, the Instructions to Bidders, the General Conditions, the plans and specifications, the bid, the Agreement, the general bond and insurance certificates. The contract documents are complementary, and what is called for by one shall be as binding as if called for by all.

2.08 PLANS AND SPECIFICATIONS. The term "Plans and Specifications", where used herein, shall mean and include all specifications and provisions of any kind, whether general, detailed or otherwise, relating to the labor, equipment, material or work in the installation thereof, and the plans and drawings, if any, accompanying same which are made a part hereof.

2.09 AGREEMENT. The Contractor to whom the Work is awarded shall, within ten days after receipt of the contract documents as mailed by the Purchasing Agent or designee, enter into an agreement with the owner. The form of agreement is attached herein and made a part of these General Conditions.

2.10 MATERIAL, LABOR, EQUIPMENT AND OTHER FACILITIES. Unless otherwise provided, the Contractor shall provide and pay for all materials, labor, water, tools, equipment, lights, power, transportation and other facilities necessary for the execution and completion of the Work.

2.11 PERMITS AND LICENSES. All permits and licenses necessary for the prosecution of the Work shall be secured and paid for by the Contractor, except those secured by Owner and so noted.

2.12 INSPECTION OF WORK. A representative of the Owner shall, at all times, have access to the Work and the Contractor shall provide proper facilities for such access and for inspection. The Contractor's attention is directed to Government Code Section 1126 and Stanislaus County regulations wherein the Owner's representative is prohibited from accepting from the Contractor, his employees, and subcontractors any gratuity, gift, service or material of any value or use of equipment or facilities, and agrees to abide by the section and regulations.

2.13 BONDS. The Contractor shall furnish and deliver to the Board a surety bond in the amount equal to one hundred percent (100%) of the contract price to guarantee the faithful performance of the contract, and a surety bond in an amount equal to one hundred percent (100%) of the contract price for the faithful payment and satisfaction of all lawful claims of all persons for labor and material furnished and the prosecution of the contract.

Such surety bonds shall be issued by a corporation duly and legally licensed to transact surety business in the State of California and approved by the Board. All participating signatures on the bonds shall be notarized.

2.14 INSURANCE.

Coverage Required: Contractor shall obtain, and maintain at all times during the term of this Agreement, insurance coverage in the amounts and coverage specified in the attached "Exhibit B."

2.15 DEFENSE AND INDEMNIFICATION.

2.15.1 Owner and each of its officers, employees, consultants and agents including, but not limited to, the Board, Project Manager and each Owner's Representative, shall not be liable or accountable in any manner for loss or damage that may happen to any part of the Work; loss or damage to materials or other things used or employed in performing the Work; injury, sickness, disease, or death of any person; or damage to property resulting from any cause whatsoever except their sole negligence, willful misconduct or active negligence, attributable to performance or character of the Work, and Contractor releases all of the foregoing persons and entities from any and all such claims.

2.15.2 To the furthest extent permitted by law (including without limitation California Civil Code §2782), Contractor shall assume defense of, and indemnify and hold harmless, Owner and each of its officers, employees, consultants and agents, including but not limited to the Board, Project Manager and each Owner's Representative, from claims, suits, actions, losses and liability of every kind, nature and description, including but not limited to claims and fines of regulatory agencies and attorney's fees and consultant's fees, directly or indirectly arising out of, connected with or resulting from performance of the Work, failure to perform the Work, or condition of the Work which is caused in whole or part by any act or omission of Contractor, Subcontractors, anyone directly or indirectly employed by any of them or anyone for whose acts any of them may be liable, resulting from any cause whatsoever except their sole negligence, willful misconduct or active negligence.

2.15.3 With respect to third-party claims against Contractor, Contractor waives any and all rights to any type of express or implied indemnity against Owner and each of its officers, employees, consultants and agents including, but not limited to Owner, the Board, Project Manager and each Owner's Representative. Owner shall provide timely notice to Contractor of any third-party claim relating to the Contract Documents, in accordance with Section 9201 of the California Public Contract Code.

2.15.4 Approval or purchase of any insurance contracts or policies shall in no way relieve from liability nor limit the liability of Contractor, its Subcontractors of any tier, or the officers or agents of any of them.

2.15.5 To the furthest extent permitted by law (including, without limitation, Civil Code §2782), the indemnities, releases of liability and limitations of liability, claims procedures, and limitations of remedy expressed throughout Contract Documents shall apply even in the event of breach of Contract, negligence (active or passive), fault or strict liability of the party(ies) indemnified, released, or limited in liability, and shall survive the termination, rescission, breach, abandonment, or completion of the Work or the terms of the Contract Documents. If Contractor fails to perform any of these defense or indemnity obligations, Owner may in its discretion back charge Contractor for Owner's costs and damages resulting therefrom and withhold such sums from progress payments or other Contract moneys which may become due.

2.15.6 The indemnities in the Contract Documents shall not apply to any indemnified party to the extent of its sole negligence or willful misconduct; nor shall they apply to Owner or other indemnified party to the extent of its active negligence.

2.16 ASSIGNMENT OF CONTRACT. Contractor shall not assign the contract or sublet it as a whole without written consent of the owner, nor shall the Contractor assign any monies due or to become due to him hereunder without the written consent of the Owner.

2.17 PREVAILING WAGES. Pursuant to Labor Code section 1771, the work under this Agreement is subject to the provisions of Article 2 (commencing with section 1770) of Chapter 1 of Part 7 of Division 2 of the Labor

Code, and the Contractor shall pay all workers the general prevailing rate of per diem wages applicable to the work to be done for straight time, overtime, Saturday, Sunday and holiday work. These wage rates, which are set forth by the Director of the Department of Industrial Relations, are now on file with the Department of Public Works and are a part of this Agreement. The Contractor shall post a copy of these prevailing wage rates on the job site.

2.18 REGISTRATION WITH THE DEPARTMENT OF INDUSTRIAL RELATIONS. No Contractor or subcontractor may be listed on a bid proposal for a public work project (submitted on or after March 1, 2015) unless registered with the Department of Industrial Relations pursuant to Labor Code section 1725.5 5 [with limited exceptions from this requirement for bid purposes only under Labor Code section 1771.1(a)]. No contractor or subcontractor may be awarded a contract for public work on a public works project (awarded on or after April 1, 2015) unless registered with the Department of Industrial Relations pursuant to Labor Code section 1725.5. This project is subject to compliance monitoring and enforcement by the Department of Industrial Relations.

CONTRACTOR HEREBY ATTESTS THAT CONTRACTOR AND ALL SUBCONTRACTORS ARE REGISTERED WITH THE DEPARTMENT OF INDUSTRIAL RELATIONS ("DIR"). Senate Bill 854 requires that all contractors performing work on any public works project valued at more than \$1,000.00 must be registered with the DIR, and that all said contractors submit certified payroll reports directly to the DIR, unless excused. Failure to comply with this sections constitutes a material breach of this contract.

2.19 PAYROLL RECORDS. Pursuant to and in accordance with the provisions Labor Code section 1776, the Contractor shall keep accurate payroll records of employees performing work under this Agreement and shall make available for inspection certified copies such payroll records.

2.20 EIGHT HOUR DAY. Pursuant to and in accordance with the provisions of Labor Code sections 1810, 1811 and 1815, the time of service of any laborer, workman, or mechanic employed upon any of the work under this Agreement is limited and restricted to eight (8) hours during any one calendar day, and forty (40) hours during any one calendar week, except that work performed by employees of Contractors in excess of eight (8) hours per day, and forty (40) hours during any one week, shall be permitted upon compensation for all hours worked in excess of eight (8) hours per day at not less than one and one-half (1-1/2) times the basic rate of pay.

2.21 REQUIRED LISTING OF PROPOSED SUBCONTRACTORS. Each bid shall have listed therein the name, license number and address of each subcontractor to whom the Bidder proposes to subcontract portions of the Work in the amount of 1/2 of one percent of his total bid or \$10,000, whichever is greater, in accordance with the Subletting and Subcontracting Fair Practices Act, commencing with Section 4100 of the Public Contract Code. A sheet for listing the subcontractors, as required herein, is included in the Bid. The Bidder's attention is invited to other provisions of said Act related to the imposition of penalties for a failure to observe its provisions by using unauthorized subcontractor or by making unauthorized substitutions.

2.22 STANDARD SPECIFICATIONS AND CODES. All Work herein specified shall be performed in accordance with applicable sections of the following Standard Specifications or Codes which are herein named and hereby made a portion of these specifications. In a case of conflict between these specifications and said Standards, these specifications shall be paramount.

Stanislaus County Code Title 16, Chap. 16.05

Stanislaus County Code Title 16, Chap. 16.10

Stanislaus County Code Title 16, Chap. 16.15

Stanislaus County Code Title 16, Chap. 16.20

Standard Specifications, State of California, Department of Transportation (2010)

Stanislaus County Improvement Standards

California Building Code (California Code of Regulations, Title 24, Part 2)

2.23 TAXES. Any federal, state or city tax payable on articles furnished by the Contractor under the contract shall be included in the contract price paid by the Contractor.

2.24 TIME FOR COMPLETION. The Work to be performed under this contract shall be completed as stated within ARTICLE IV of this Agreement.

2.25 DEFECTS IN WORK. The Contractor shall be responsible for and must make good any defects through faulty, improper or inferior workmanship or materials arising or discovered in any part of this work within one (1) year after the completion and acceptance of the same.

2.26 DEVIATION FROM PLANS AND SPECIFICATIONS. No deviation shall be made from the plans and specifications. If the Contractor shall vary from the plans and specifications in the form of quality or in the Work or the amount or value of the materials herein provided for, the Owner shall have the right to order such improper work or materials removed, remade or replaced. In the event that the Work is ordered changed, any other work disturbed or damaged by such alteration shall be made good at the Contractor's expense.

2.27 BRANDS. Wherever the name or brand of a manufacturer or an article is specified herein, it is used as a measure of quality and utility or a standard. If the Contractor desires to use any other brand or manufacturer of equal quality and utility to that specified, he shall make application to the Owner in writing and submit samples, if requested. The Contractor shall have 35 days after the award of the contract for submission of data substantiating any such request for substitution of "equal" items. The Owners will then determine whether or not the name brand or article is equal in quality and utility to that specified, and its decision shall be final.

Except in those instances in which the product is designated to match others presently in use, specifications herein calling for a designated material, product, thing or service by specific brand or trade name shall be deemed to be followed by the words "or equal" so that Contractor may furnish any equal material, product, thing or service. The Contractor shall have thirty-five (35) days after award of the contract for submission of data substantiating a request for a substitution of "an equal" item, pursuant to Section 3400 of the Public Contract Code.

2.28 NEW MATERIALS. All materials used in the Work shall be new and the best market quality, unless specified or shown otherwise. All labor used on this contract shall be competent and skilled for the Work. All Work executed under this contract shall be done in the best, most thorough substantial and workmanlike manner. All material and labor shall be subject to the approval of the Engineer as to quality and fitness, and shall be immediately removed if it does not meet with his approval.

2.29 ABANDONMENT OF WORK. Should the Contractor abandon the Work called for under the plans and specifications and contract documents, or assign his contract, or if the Contractor unnecessarily and unreasonably delays the Work, or if the Contractor willfully violates any of the conditions of the plans and specifications or contract documents, or performs the Work in bad faith, the Owner shall have the power to notify the Contractor to discontinue all work or any part thereof under this contract, and thereupon the Contractor shall cease to continue said work or such part thereof as the Owner may designate, and the Owner shall thereupon have the power to employ such persons as it may consider desirable, and to obtain by contract, purchase, hire or otherwise, such implements, tools, material or materials as the Owner may deem advisable to work at and be used to complete the Work herein described, or such part thereof as shall have not been completed, and to use such material as it may find upon the site of said Work, and to charge the expense of such labor and material, implements and tools to the Contractor, and the expense so charged shall be deducted and paid by the Owner out of such monies as may be either due, or may at any time thereafter become due to the Contractor hereunder and by virtue of the contract.

In the case such expense is less than the sum which would have been payable under the contract, if the same had been completed by the Contractor, the Contractor shall be entitled to receive the difference, and in case such expense shall exceed the last said amount, then the Contractor or his bondsman shall pay the amount of such excess to the Owner on notice to either from the Owner the excess so due.

2.30 EXTENSION OF TIME. If it appears to the Contractor that he will not complete the Work herein specified in the time agreed, he shall make written application to the Owner at least five (5) calendar days prior to the expiration of the time for completion, stating the reasons why and the amount of extension which he believes he should be granted. The Owner may then, in its discretion, grant or deny such extension.

2.31 SUSPENSION OF WORK. Should the Owner, for any cause, authorize a suspension of Work, the time of such suspension will be added to the time allowed for completion. Suspension of Work by order of the Board shall not be deemed a waiver of the claim of the Owner for damages for non-completion of the Work as above required.

2.32 JUSTIFIABLE DELAYS. The Contractor shall not be held responsible for delays in the completion of the Work caused by strikes, labor disturbances, lack or failure of transportation, war, inability to obtain materials due to war conditions, perils of the sea, insurrection, riot, acts of any government, whether foreign or domestic, federal or state, and/or any other causes similar to the foregoing which are beyond the control of and are not the fault of the Contractor, or if prevented by conditions directly resulting from the execution of contracts or the placing of orders by the Federal government or its authorized agencies or representatives, which are required by law to be given priority, but provided that whenever the Contractor shall claim that delays are due to any or all of the above named cause or causes of delay, request an extension of time in accordance with paragraph 2.27 of these General Conditions, and if the Board finds that such cause or causes of delay exist, it shall grant him an extension of time equal to the delay resulting from such cause or causes, or the Board may at its option, rescind said contract and pay said Contractor for the reasonable value of the Work completed and let a new contract for the completion of the remainder of the Work herein specified.

2.33 PATENTS AND ROYALTIES. If any material, composition, process or any other thing called for or required by the plans and specifications heretofore adopted by the Owner is covered by letter patent, all royalties and expenses thereof, all litigation therefrom, or other things whatsoever which may develop as a cost from the use of such material, composition, process or any other thing which is covered by letter patents shall be borne by the Contractor. The Contractor shall pay all license and/or royalty fees. He shall defend all suits or claims for infringement of any patent rights and shall save the Owner harmless from loss on account thereof.

2.34 EXAMINATION OF SITE. The Contractor shall be held to have examined the site, compared it with the drawings and specifications, and to have satisfied himself as to the conditions under which the Work is to be performed. No allowance or claims on his behalf will be made for any expense to which he may be put as a result or failure on his part to thoroughly acquaint himself with conditions at the site.

2.35 DAMAGE TO OTHERS. The Contractor shall exercise due caution during his operations so as not to damage the property of others or Owner's property not directly involved under the plans and specifications, and shall be responsible for the protection of this property and shall replace any and all such property to its former condition as a result of his failure to provide protection or exercise due caution during his operations.

2.36 SURVEYS AND GRADES. The Engineer shall establish permanent type reference monuments or posts for the alignment and elevations of all Work. For structures he will provide said monuments for reference data only. For general engineering contracts he shall provide the usual stakes sufficient for construction. The Contractor shall be charged with the responsibility of adequately protecting said stakes and monuments. The Contractor shall be requested to set supplemental posts for detailed construction needs.

2.37 CORRECTION OF WORK AFTER FINAL PAYMENT. Neither the final certificate nor final payment, nor any provision of the contract documents shall relieve the Contractor of responsibility for faulty materials or workmanship, and unless otherwise specified, he shall remedy any defects due thereto and shall pay for any damage or other work resulting therefrom which shall appear within a period of one year from the date of substantial completion. The Owner shall give notice of observed defects with reasonable promptness. All questions arising under this article shall be decided by the Board.

2.38 CHANGES IN WORK. The Owner, without invalidating the contract, may order extra work or make changes by altering, adding to or deducting from the Work, the contract sum being adjusted accordingly. All such work shall be performed under the conditions of the contract except that any claim for extension of time caused thereby shall be adjusted at the time of ordering the change. The Engineer shall have authority to make minor changes not involving extra cost and not inconsistent with the purpose of the Project.

The value of such extra Work or change shall be determined in one or more of the following ways:

- (a) By estimate and acceptance in a lump sum;
- (b) By unit prices named in the contract or subsequently agreed upon;
- (c) By cost and percentage and fixed fee.

Should conditions below surface of the ground be at variance with the conditions indicated by the drawings and specifications, the contract sum shall be equitably adjusted upon claim by either party made within a reasonable time after first observation of conditions.

The amount agreed upon as the value of any extra Work resulting from any change order shall constitute full and complete compensation for all overhead, labor, material, tools, and equipment furnished in the performance of Work required by that change order. Furthermore, the amount agreed upon as the value of extra Work for any change order shall be accepted by the Contractor as full and complete compensation for any and all claims of any nature whatsoever, including, but not limited to, any actual or alleged claims for compensation by Contractor, or any subcontractor of Contractor for delays occasioned by or in any way arising out of stoppage of the Work, coordination of the Work with others, or processing of that change order.

2.39 CLEANING UP. Contractor shall at all times keep the premises free from accumulations of waste material or rubbish as a result of this operation. Upon completion of Work he shall remove all rubbish, material and his equipment from the job and shall leave the job site in a "broom clean" or equivalent condition. In case of a dispute regarding this item, the Owner may remove rubbish or material and charge the cost to the several contractors as the authorized representative shall deem just.

2.40 SUPERVISION. The Contractor shall, at all times during the working hours of the contract, have a competent foreman or superintendent on the job who shall be authorized to act as an agent of the Contractor. Such agent shall be familiar with the type of work hereunder and be aware of the hazards and the safety rules relating to this particular type of construction. Ignorance or incompetence of a foreman shall be due cause for his removal from the job and cessation of work under this contract until the intent of this paragraph is fulfilled, without recourse by the Contractor for any extension of the time of completion as a result of the removal of such unsatisfactory agent.

2.41 APPRENTICESHIP STANDARDS. This contract is subject to the provisions in Sections 1777.5 (Chapter 1411, Statutes of 1968) and 1777.6 of the Labor Code concerning the employment of apprentices by the Contractor or any subcontractor under the Contractor. Section 1777.5, as amended, requires the Contractor or subcontractor employing tradesmen in any apprenticeable occupation to apply to the Joint Apprenticeship Committee nearest the site of the public works project and which administers the apprenticeship program in that trade for a certificate of approval. The certificate will also fix the ratio of apprentices to journeymen that will be used in the performance of the contract. The ratio of apprentices to journeymen in such cases shall not be less than one to five, except:

- (a) When unemployment in the area of coverage by the Joint Apprenticeship Committee has exceeded an average of fifteen percent (15%) in the three (3) months prior to the request for certificate; or
- (b) When the number of apprentices in training in the area exceeds a ratio of one to five; or
- (c) When the trade can show that it is replacing at least 1/30 of its journeymen through apprenticeship training on an annual basis statewide or locally; or
- (d) Assignment of an apprentice to any work performed under a public works contract would create a condition that would jeopardize his or her life or the life, safety, or property of fellow employees or the public at large, or the specific task to which the apprentice is to be assigned is of a nature that training cannot be provided by a journeyman.

The Contractor is required to make contributions to funds established for the administration of apprenticeship programs if he employees registered apprentices or journeymen in any apprenticeable trade on such contracts and if other contractors on the public works site are making such contributions.

The Contractor and any subcontractor under him shall comply with the requirements of Sections 1777.5 and 1777.6 in the employment of apprentices.

Information relative to apprenticeship standards, wage schedules, and other requirements may be obtained from the Administrator of Apprenticeship, San Francisco, California, or from the Division of Apprenticeship Standards and its branch offices.

2.42 ASSIGNMENT OF ANTI-TRUST ACTIONS AND UNFAIR BUSINESS PRACTICE CLAIMS. In entering into a public works contract or a subcontract to supply goods, services, or materials pursuant to a public works contract, the Contractor or subcontractor offers and agrees to assign to the awarding body all rights, title, and interest in and to all causes of action it may have under Section 4 of the Clayton Act (15 U.S.C. Sec. 15) or under the Cartwright Act (Chapter 2 (commencing with section 16700) of Part 2 of Division 7 of the Business and Professions Code), arising from purchases of goods, services, or materials pursuant to the public works contract or the subcontract. This assignment shall be made and become effective at the time the awarding body tenders final payment to the Contractor, without further acknowledgment by the parties.

2.43 EQUAL EMPLOYMENT OPPORTUNITY. During the performance of this Agreement, Contractor and its officers, employees, agents, representatives or subcontractors shall not unlawfully discriminate in violation of any Federal, State or local law, rule or regulation against any employee, applicant for employment or person receiving services under this Agreement because of race, religious creed, color, national origin, ancestry, physical or mental disability including perception of disability, medical condition, genetic information, pregnancy related condition, marital status, gender/sex, sexual orientation, gender identity, gender expression, age (over 40), political affiliation or belief, or military and veteran status. The Contractor agrees to post in conspicuous places, available to employees and applicants for employment, notices to be provided setting forth the provisions of this nondiscrimination clause.

The Contractor will in all solicitations or advertisements for employees placed by or on behalf of the Contractor, state that all qualified applicants will receive consideration for employment without regard to race, religious creed, color, national origin, ancestry, physical or mental disability including perception of disability, medical condition, genetic information, pregnancy related condition, marital status, gender/sex, sexual orientation, gender identity, gender expression, age (over 40), political affiliation or belief, or military and veteran status.

The Contractor will send to each labor union or other representative of workers with which it has a collective bargaining agreement or other contract or understanding, a notice advising the workers' representative of the Contractor commitments under this agreement.

The Contractor agrees that it will comply with the provisions of Titles VI and VII of the Civil Rights Act, Revenue Sharing Act Title 31, U.S. Code Section 2716, and California Government Code Section 12990.

The Contractor agrees that it will assist and cooperate with the County of Stanislaus, the State of California and the United States Government in obtaining compliance with the equal opportunity clause, rules, regulations, and relevant orders of the State of California and United States Government issued pursuant to the Acts.

In the event of the Contractor's non-compliance with the discrimination clause, the affirmative action plan of this contract, or with any of the said rules, regulations or orders, this contract may be canceled, terminated, or suspended in whole or in part by the Owner.

2.44 DISABLED INDIVIDUALS NON-DISCRIMINATION. This Project is subject to Section 504 of the Rehabilitation Act of 1973 as amended (29 U.S.C. 794) and all requirements imposed by Title II of the Americans with Disabilities Act (42 U.S.C. 12132) and all guidelines and interpretations issued thereto. In this regard, the

Owner and all of its contractors and subcontractors will take all reasonable steps to ensure that disabled individuals have the maximum opportunity for the same level of aid, benefit or service as any other individual.

2.45 FAIR EMPLOYMENT AND HOUSING ACT ADDENDUM. During the performance of this Agreement, Contractor and its officers, employees, agents, representatives or subcontractors shall not unlawfully discriminate in violation of any Federal, State or local law, rule or regulation against any employee, applicant for employment or person receiving services under this Agreement because of race, religious creed, color, national origin, ancestry, physical or mental disability including perception of disability, medical condition, genetic information, pregnancy related condition, marital status, gender/sex, sexual orientation, gender identity, gender expression, age (over 40), political affiliation or belief, or military and veteran status. Contractor and its officers, employees, agents, representatives or subcontractors shall comply with all applicable Federal, State and local laws and regulations related to non-discrimination and equal opportunity, including without limitation the County's non-discrimination policy; the Fair Employment and Housing Act (Government Code sections 12900 et seq.); California Labor Code sections 1101 and 1102; the Federal Civil Rights Act of 1964 (P.L. 88-352), as amended; and all applicable regulations promulgated in the California Code of Regulations or the Code of Federal Regulations. Such action shall include, but not be limited to, the following: employment, upgrading, promotion or transfer; recruitment or recruitment advertising; layoff or termination; rates of pay or other forms of compensation; and selection for training, including apprenticeship. The Contractor shall post in conspicuous places, available to employees and applicants for employment, notices to be provided by the State or local agency setting forth the provisions of this Fair Employment and Housing Section.

The Contractor will permit access to his records of employment, employment advertisements, application forms, and other pertinent data and records by the State Fair Employment and Housing Commission, or any other agency of the State of California designated by the awarding authority, for the purposes of investigation to ascertain compliance with the Fair Employment and Housing section of this contract.

Remedies for willful violation include:

(a) The State or local agency may determine a willful violation of the Fair Employment and Housing provision to have occurred upon receipt of a final judgement having that effect from a court in an action to which Contractor was a party; or upon receipt of a written notice from the Fair Employment and Housing Commission that it has investigated and determined that the Contractor has violated the Fair Employment and Housing Act and has issued an order or obtained an injunction under Government Code Section 12900, et seq.

(b) For willful violation of this Fair Employment and Housing provision the State or local agency shall have the right to terminate this contract either in whole or in part, and any loss or damage sustained by the State or local agency in securing the goods or services hereunder shall be borne and paid for by the Contractor and by his surety under the performance bond, if any, and the State or local agency may deduct from any monies due or that thereafter may become due to the Contractor, the difference between the price named in the contract and the actual cost thereof to the State or local agency.

2.46 DIGGING TRENCHES OR EXCAVATIONS.

2.46.1 Trenching shall be done in accordance with the California Labor Code Section 6705, 6706, and 6707.

2.46.2 Pursuant to Public Contract Code section 7104, the Contractor is hereby notified as follows:

Any public works contract of a local public entity which involves digging trenches or other excavations that extend deeper than four feet below the surface and shall contain a clause which provides the following:

(a) That the Contractor shall promptly, and before the following conditions are disturbed, notify the public entity, in writing, of any:

- (1) Material that the Contractor believes may be material that is hazardous waste, as defined in Section 25117 of the Health and Safety Code, that is required to be removed to a Class I, Class II, or Class III disposal site in accordance with provisions of existing law.
- (2) Subsurface or latent physical conditions at the site differing from those indicated.
- (3) Unknown physical conditions at the site of any unusual nature, different materially from those ordinarily encountered and generally recognized as inherent in work of the character provided for in the contract.

(b) That the public entity shall promptly investigate the conditions, and if it finds that the conditions do materially so differ, or do involve hazardous waste, and cause a decrease or increase in the contractor's cost of, or the time required for, performance of any part of the Work shall issue a change order under the procedures described in the contract.

(c) That, in the event that a dispute arises between the public entity and the contractor whether the conditions materially differ, or involve hazardous waste, or cause a decrease or increase in the contractor's cost of, or time required for, performance of any part of the Work, the contractor shall not be excused from any scheduled completion date provided for by the contract, but shall proceed with all work to be performed under the contract. The Contractor shall retain any and all rights provided either by contract or by law which pertain to the resolution of disputes and protests between the contracting parties.

2.46.3 Digging trenches or excavations shall be in accordance with the California Government Code Section 4216, the California Business and Professions Code Section 7110 and the CalOSHA Regulation Title 8 Chapter 4 Subchapter 4 Article 6 Section 1541.

2.47 UTILITY RELOCATION. Pursuant to Government Code section 4215, the Contractor shall be compensated for the costs of locating, repairing damage not due to the failure of the Contractor to exercise reasonable care, and removing or relocating such utility facilities not indicated in the plans and specifications with reasonable accuracy, and for equipment on the project necessarily idled during such work. The Contractor shall not be assessed liquidated damages for delay in completion of the project, when such delay is caused by the failure of the County of the utility owner to provide for removal or relocation of such utility facilities.

2.48 NOTICE

Any notice, communication, amendment, addition or deletion to this Agreement, including change of address of either party during the term of this Agreement, which Contractor or County shall be required or may desire to make shall be in writing and may be personally served or, alternatively, sent by prepaid first class mail to the respective parties as follows:

To County:	County of Stanislaus Purchasing Agent 1010 10 th Street, Suite 5400 Modesto, CA 95354
To Contractor:	Elevator Industries Inc. Guy Buckman General Manager 110 Main Ave. Sacramento CA 95838

2.49 FINAL PAYMENT.

A. FINAL PAYMENT

1. As soon as practicable after all required Work is completed in accordance with Contract Documents, including punch list, testing, record documents and Contractor maintenance after Final Acceptance, Contractor shall submit its Application for Final Payment.
2. Provided Contractor has met all conditions required for Final payment, Owner will pay to Contractor, in manner provided by law, unpaid balance of Contract Sum of Work (including, without limitation, retentions), or whole Contract Sum of Work if no progress payment has been made, determined in accordance with terms of Contract Documents, less sums as may be lawfully retained under any provisions of Contract Documents or by law.

B. FINAL ACCOUNTING

1. Prior progress payments and change orders shall be subject to audit and correction in the final payment.
2. Contractor and each assignee under an assignment in effect at time of final payment shall execute and deliver at time of final payment, and as a condition precedent to final payment, an Agreement and Release of Claims.

2.50 CLAIMS UNDER \$375,000.

The provision of Article 1.5 (commencing with section 20104) of Chapter 1 of Part 3 of the Public Contract Code, relating to the resolution of construction Claims of three hundred seventy-five thousand dollars (\$375,000) or less which arise between a contractor and a local agency are hereby incorporated in this Contract and set forth below.

20104. (a) (1) This article applies to all public works claims of three hundred seventy-five thousand dollars (\$375,000) or less which arise between a contractor and a local agency.

(2) This article shall not apply to any claims resulting from a contract between a contractor and a public agency when the public agency has elected to resolve any disputes pursuant to Article 7.1 (commencing with Section 10240) of Chapter 1 of Part 2.

(b) (1) "Public work" has the same meaning as in Sections 3100 and 3106 of the Civil Code, except that "public work" does not include any work or improvement contracted for by the state or the Regents of the University of California.

(2) "Claim" means a separate demand by the contractor for (A) a time extension, (B) payment of money or damages arising from work done by, or on behalf of, the contractor pursuant to the contract for a public work and payment of which is not otherwise expressly provided for or the claimant is not otherwise entitled to, or (C) an amount the payment of which is disputed by the local agency.

(c) The provisions of this article or a summary thereof shall be set forth in the plans or specifications for any work which may give rise to a claim under this article.

(d) This article applies only to contracts entered into on or after January 1, 1991.

20104.2. For any claim subject to this article, the following requirements apply:

(a) The claim shall be in writing and include the documents necessary to substantiate the claim. Claims must be filed on or before the date of final payment. Nothing in this subdivision is intended to extend the time limit or supersede notice requirements otherwise provided by contract for the filing of claims.

(b) (1) For claims of less than fifty thousand dollars (\$50,000), the local agency shall respond in writing to any written claim within 45 days of receipt of the claim, or may request, in

writing, within 30 days of receipt of the claim, any additional documentation supporting the claim or relating to defenses to the claim the local agency may have against the claimant.

(2) If additional information is thereafter required, it shall be requested and provided pursuant to this subdivision, upon mutual agreement of the local agency and the claimant.

(3) The local agency's written response to the claim, as further documented, shall be submitted to the claimant within 15 days after receipt of the further documentation or within a period of time no greater than that taken by the claimant in producing the additional information, whichever is greater.

(c) (1) For claims of over fifty thousand dollars (\$50,000) and less than or equal to three hundred seventy-five thousand dollars (\$375,000), the local agency shall respond in writing to all written claims within 60 days of receipt of the claim, or may request, in writing, within 30 days of receipt of the claim, any additional documentation supporting the claim or relating to defenses to the claim the local agency may have against the claimant.

(2) If additional information is thereafter required, it shall be requested and provided pursuant to this subdivision, upon mutual agreement of the local agency and the claimant.

(3) The local agency's written response to the claim, as further documented, shall be submitted to the claimant within 30 days after receipt of the further documentation, or within a period of time no greater than that taken by the claimant in producing the additional information or requested documentation, whichever is greater.

(d) If the claimant disputes the local agency's written response, or the local agency fails to respond within the time prescribed, the claimant may so notify the local agency, in writing, either within 15 days of receipt of the local agency's response or within 15 days of the local agency's failure to respond within the time prescribed, respectively, and demand an informal conference to meet and confer for settlement of the issues in dispute. Upon a demand, the local agency shall schedule a meet and confer conference within 30 days for settlement of the dispute.

(e) Following the meet and confer conference, if the claim or any portion remains in dispute, the claimant may file a claim as provided in Chapter 1 (commencing with Section 900) and Chapter 2 (commencing with Section 910) of Part 3 of Division 3.6 of Title 1 of the Government Code. For purposes of those provisions, the running of the period of time within which a claim must be filed shall be tolled from the time the claimant submits his or her written claim pursuant to subdivision (a) until the time that claim is denied as a result of the meet and confer process, including any period of time utilized by the meet and confer process.

(f) This article does not apply to tort claims and nothing in this article is intended nor shall be construed to change the time periods for filing tort claims or actions specified by Chapter 1 (commencing with Section 900) and Chapter 2 (commencing with Section 910) of Part 3 of Division 3.6 of Title 1 of the Government Code.

20104.4. The following procedures are established for all civil actions filed to resolve claims subject to this article:

(a) Within 60 days, but no earlier than 30 days, following the filing or responsive pleadings, the court shall submit the matter to nonbinding mediation unless waived by mutual stipulation of both parties. The mediation process shall provide for the selection within 15 days by both parties of a disinterested third person as mediator, shall be commenced within 30 days of the submittal, and shall be concluded within 15 days from the commencement of the mediation unless a time requirement is extended upon a good cause showing to the court or by stipulation of both parties. If the parties fail to select a mediator within the 15-day period, any party may petition the court to appoint the mediator.

(b) (1) If the matter remains in dispute, the case shall be submitted to judicial arbitration pursuant to Chapter 2.5 (commencing with Section 1141.10) of Title 3 of Part 3 of the Code of Civil Procedure, notwithstanding Section 1141.11 of that code. The Civil Discovery Act (Title 4 (commencing with Section 2016.010) of Part 4 of the Code of Civil Procedure) shall apply to any proceeding brought under this subdivision consistent with the rules pertaining to judicial arbitration.

(2) Notwithstanding any other provision of law, upon stipulation of the parties, arbitrators appointed for purposes of this article shall be experienced in construction law, and, upon stipulation of the parties, mediators and arbitrators shall be paid necessary and reasonable hourly

rates of pay not to exceed their customary rate, and such fees and expenses shall be paid equally by the parties, except in the case of arbitration where the arbitrator, for good cause, determines a different division. In no event shall these fees or expenses be paid by state or county funds.

(3) In addition to Chapter 2.5 (commencing with Section 1141.10) of Title 3 of Part 3 of the Code of Civil Procedure, any party who after receiving an arbitration award requests a trial de novo but does not obtain a more favorable judgment shall, in addition to payment of costs and fees under that chapter, pay the attorney's fees of the other party arising out of the trial de novo.

(c) The court may, upon request by any party, order any witnesses to participate in the mediation or arbitration process.

20104.6. (a) No local agency shall fail to pay money as to any portion of a claim which is undisputed except as otherwise provided in the contract.

(b) In any suit filed under Section 20104.4, the local agency shall pay interest at the legal rate on any arbitration award or judgment. The interest shall begin to accrue on the date the suit is filed in a court of law.

2.51 ALL CLAIMS.

Notwithstanding section 2.50, the provisions of Chapter 9 (commencing with section 9204) of the Public Contracts Code shall apply to any Claims under this Contract; and is hereby incorporated into this contract as set forth below.

9204. (a) The Legislature finds and declares that it is in the best interests of the state and its citizens to ensure that all construction business performed on a public works project in the state that is complete and not in dispute is paid in full and in a timely manner.

(b) Notwithstanding any other law, including, but not limited to, Article 7.1 (commencing with Section 10240) of Chapter 1 of Part 2, Chapter 10 (commencing with Section 19100) of Part 2, and Article 1.5 (commencing with Section 20104) of Chapter 1 of Part 3, this section shall apply to any claim by a contractor in connection with a public works project.

(c) For purposes of this section:

(1) "Claim" means a separate demand by a contractor sent by registered mail or certified mail with return receipt requested, for one or more of the following:

(A) A time extension, including, without limitation, for relief from damages or penalties for delay assessed by a public entity under a contract for a public works project.

(B) Payment by the public entity of money or damages arising from work done by, or on behalf of, the contractor pursuant to the contract for a public works project and payment for which is not otherwise expressly provided or to which the claimant is not otherwise entitled.

(C) Payment of an amount that is disputed by the public entity.

(2) "Contractor" means any type of contractor within the meaning of Chapter 9 (commencing with Section 7000) of Division 3 of the Business and Professions Code who has entered into a direct contract with a public entity for a public works project.

(3) (A) "Public entity" means, without limitation, except as provided in subparagraph (B), a state agency, department, office, division, bureau, board, or commission, the California State University, the University of California, a city, including a charter city, county, including a charter county, city and county, including a charter city and county, district, special district, public authority, political subdivision, public corporation, or nonprofit transit corporation wholly owned by a public agency and formed to carry out the purposes of the public agency.

(B) "Public entity" shall not include the following:

(i) The Department of Water Resources as to any project under the jurisdiction of that department.

(ii) The Department of Transportation as to any project under the jurisdiction of that department.

(iii) The Department of Parks and Recreation as to any project under the jurisdiction of that department.

(iv) The Department of Corrections and Rehabilitation with respect to any project under its jurisdiction pursuant to Chapter 11 (commencing with Section 7000) of Title 7 of Part 3 of the Penal Code.

(v) The Military Department as to any project under the jurisdiction of that department.

(vi) The Department of General Services as to all other projects.

(vii) The High-Speed Rail Authority.

(4) "Public works project" means the erection, construction, alteration, repair, or improvement of any public structure, building, road, or other public improvement of any kind.

(5) "Subcontractor" means any type of contractor within the meaning of Chapter 9 (commencing with Section 7000) of Division 3 of the Business and Professions Code who either is in direct contract with a contractor or is a lower tier subcontractor.

(d) (1) (A) Upon receipt of a claim pursuant to this section, the public entity to which the claim applies shall conduct a reasonable review of the claim and, within a period not to exceed 45 days, shall provide the claimant a written statement identifying what portion of the claim is disputed and what portion is undisputed. Upon receipt of a claim, a public entity and a contractor may, by mutual agreement, extend the time period provided in this subdivision.

(B) The claimant shall furnish reasonable documentation to support the claim.

(C) If the public entity needs approval from its governing body to provide the claimant a written statement identifying the disputed portion and the undisputed portion of the claim, and the governing body does not meet within the 45 days or within the mutually agreed to extension of time following receipt of a claim sent by registered mail or certified mail, return receipt requested, the public entity shall have up to three days following the next duly publicly noticed meeting of the governing body after the 45-day period, or extension, expires to provide the claimant a written statement identifying the disputed portion and the undisputed portion.

(D) Any payment due on an undisputed portion of the claim shall be processed and made within 60 days after the public entity issues its written statement. If the public entity fails to issue a written statement, paragraph (3) shall apply.

(2) (A) If the claimant disputes the public entity's written response, or if the public entity fails to respond to a claim issued pursuant to this section within the time prescribed, the claimant may demand in writing an informal conference to meet and confer for settlement of the issues in dispute. Upon receipt of a demand in writing sent by registered mail or certified mail, return receipt requested, the public entity shall schedule a meet and confer conference within 30 days for settlement of the dispute.

(B) Within 10 business days following the conclusion of the meet and confer conference, if the claim or any portion of the claim remains in dispute, the public entity shall provide the claimant a written statement identifying the portion of the claim that remains in dispute and the portion that is undisputed. Any payment due on an undisputed portion of the claim shall be processed and made within 60 days after the public entity issues its written statement. Any disputed portion of the claim, as identified by the contractor in writing, shall be submitted to nonbinding mediation, with the public entity and the claimant sharing the associated costs equally. The public entity and claimant shall mutually agree to a mediator within 10 business days after the disputed portion of the claim has been identified in writing. If the parties cannot agree upon a mediator, each party shall select a mediator and those mediators shall select a qualified neutral third party to mediate with regard to the disputed portion of the claim. Each party shall bear the fees and costs charged by its respective mediator in connection with the selection of the neutral mediator. If mediation is unsuccessful, the parts of the claim remaining in dispute shall be subject to applicable procedures outside this section.

(C) For purposes of this section, mediation includes any nonbinding process, including, but not limited to, neutral evaluation or a dispute review board, in which an independent third party or board assists the parties in dispute resolution through negotiation or by issuance of an evaluation. Any mediation utilized shall conform to the timeframes in this section.

(D) Unless otherwise agreed to by the public entity and the contractor in writing, the mediation conducted pursuant to this section shall excuse any further obligation under Section 20104.4 to mediate after litigation has been commenced.

(E) This section does not preclude a public entity from requiring arbitration of disputes under private arbitration or the Public Works Contract Arbitration Program, if mediation under this section does not resolve the parties' dispute.

(3) Failure by the public entity to respond to a claim from a contractor within the time periods described in this subdivision or to otherwise meet the time requirements of this section shall result in the claim being deemed rejected in its entirety. A claim that is denied by reason of the public entity's failure to have responded to a claim, or its failure to otherwise meet the time requirements of this section, shall not

constitute an adverse finding with regard to the merits of the claim or the responsibility or qualifications of the claimant.

(4) Amounts not paid in a timely manner as required by this section shall bear interest at 7 percent per annum.

(5) If a subcontractor or a lower tier subcontractor lacks legal standing to assert a claim against a public entity because privity of contract does not exist, the contractor may present to the public entity a claim on behalf of a subcontractor or lower tier subcontractor. A subcontractor may request in writing, either on his or her own behalf or on behalf of a lower tier subcontractor, that the contractor present a claim for work which was performed by the subcontractor or by a lower tier subcontractor on behalf of the subcontractor. The subcontractor requesting that the claim be presented to the public entity shall furnish reasonable documentation to support the claim. Within 45 days of receipt of this written request, the contractor shall notify the subcontractor in writing as to whether the contractor presented the claim to the public entity and, if the original contractor did not present the claim, provide the subcontractor with a statement of the reasons for not having done so.

(e) The text of this section or a summary of it shall be set forth in the plans or specifications for any public works project that may give rise to a claim under this section.

(f) A waiver of the rights granted by this section is void and contrary to public policy, provided, however, that (1) upon receipt of a claim, the parties may mutually agree to waive, in writing, mediation and proceed directly to the commencement of a civil action or binding arbitration, as applicable; and (2) a public entity may prescribe reasonable change order, claim, and dispute resolution procedures and requirements in addition to the provisions of this section, so long as the contractual provisions do not conflict with or otherwise impair the timeframes and procedures set forth in this section.

(g) This section applies to contracts entered into on or after January 1, 2017.

(h) Nothing in this section shall impose liability upon a public entity that makes loans or grants available through a competitive application process, for the failure of an awardee to meet its contractual obligations.

(i) This section shall remain in effect only until January 1, 2020, and as of that date is repealed, unless a later enacted statute, that is enacted before January 1, 2020, deletes or extends that date.

2.52 EXAMINATION AND AUDIT. Any contract exceeding \$10,000.00 is subject to examination and audit of the California State Auditor, at the request of the County for a period of three (3) years after the final payment under the contract (pursuant to Public Contract Code section 8546.7).

EXHIBIT A

TO

AGREEMENT FOR PUBLIC WORKS OF IMPROVEMENT

(SEE SCOPE OF WORK FOR ELEVATOR MODERNIZATION AT MEN'S JAIL FROM BID NO. 17-22-BD AND ADDENDA THERETO, AND CONTRACTOR'S BID PRICING SUBMITTED THERETO, ATTACHED HERETO AND MADE A PART OF THIS AGREEMENT)

**Exhibit #A
To
BID 17-22-BD:**

Elevator Modernization at Men's Jail

SCOPE OF SERVICES

PART 1 – GENERAL

This Agreement covers one (1) projects: the complete modernization of ONE (1) traction type elevator located at 1115 H. Street, Modesto, CA 95354. State ID 030125. All work will be performed in a workmanlike manner and will include all work and material as specified herein. In all cases where a device or part of equipment is herein referred to in the singular number, it is intended that such reference will apply to as many such devices as are required to complete the installation.

- 1.1. All work will be performed in accordance with the most applicable edition of the National Safety Code for Elevators, Dumbwaiters, Escalators, and Moving Walks (ASME A17.1), ANSI A117.1 Barrier Free Code as pertaining to Passenger Elevators, the Americans with Disabilities Act (ADA), the National Electrical Code, and/or such State and Local elevator codes as may be applicable.
- 1.2. Drawings. Contractor will prepare drawings and/or cut sheets at its sole cost, showing the general arrangement of the elevator equipment (including machine room layout, hoistway plan if applicable, and section views), signal fixtures, and rope gripper mounting drawing and design if applicable, and cab drawings.
- 1.3. Permits, taxes and licenses. All applicable sales and use taxes, permit fees and licenses, as of the date bids are taken, will be paid by the Contractor.
- 1.4. Maintenance service. Interim maintenance is to be included in the price. Upon completion of the modernization start-up, maintenance will resume with the modernization contractor through the end of the fiscal year, June 30, 2016. The elevator maintenance cost will be determined by the previously agreed maintenance costs provided by the County's current service provider. County's current service provider will review job condition before substantial completion.
- 1.5. Wiring diagrams. Two (2) complete sets of "made final" wiring diagrams including input and output signals will be furnished to the County.
- 1.6. Keys. Two (2) keys for each key switch specified will be furnished to the County.
- 1.7. Warranty. Elevator contractor will warrant the materials and installation of the elevator for (2) TWO years from time of beneficial use or substantial completion, whichever comes first.

PART 2 – EQUIPMENT AND SUMMARY OF WORK.

	SAMPLE OF HYDRAULIC:	CURRENT MONTGOMERY ELEVATOR INFORMATION
Quantity:	One (1) Passenger Traction Elevator	INSTALLED: 1955
Capacity:	*3500	MODEL: Montgomery
Speed:	*100 FPM (field verify)	CONTROLS: Elevator Controls
Stops:	*Four (4)	
Openings:	*Four (4)	
Car size/Platform:	Retain existing	
Clear inside:	Retain existing	
Travel:	Retain existing	
Sling & platform	Retain existing	
Power supply:	208 VAC /(field verify)	
Logic Control:	New non-proprietary microprocessor	
Car Enclosure:	Retain Existing	
Signals & Fixtures:	New ADA vandal resistant / by code	
Doors:	Retain existing	
Door Operation:	New closed-loop design	
Operation:	Simplex Selective Collective	

PART 3 - MODERNIZATION EQUIPMENT FEATURES.

3.1 CAR.

- 3.1.1 **Car Frame and Platform:** Retain existing car sling and platform. Modify as required to accommodate any new accessories or control equipment installed. Address toe guards.
- 3.1.2 Piping: Provide all necessary pipe and fittings to connect the power unit to the jack unit shall be furnished on hydraulic units.
- 3.1.3 Controller / leveling system:
- 3.1.4 **Car and Counterweight Guide Assemblies:** Retain and rebuild the existing guide roller assemblies. Replace rollers with new neoprene tires to insure smooth ride characteristics.

3.2 CAR ENCLOSURE.

- 3.2.1 **Cab Interior/Cab:** Remove the existing cab interior. Furnish and install one (1) new cab interiors. Style to be determined at the PRE-BID JOB WALK.
- 3.2.2 **Front Returns:** Stainless steel #4.
- 3.2.3 **Car Doors:** Furnish and install new car doors. Style to be determined at the PRE-BID JOB WALK.
- 3.2.4 **Handrails:** 1 1/2" Diameter cylindrical handrail on rear wall. The new handrail shall be manufactured of stainless steel with a #4 finish.
- 3.2.5 **Canopy:** Retain existing
- 3.2.6 **Ceiling:** T-Bat type with Stainless Steel #4 frame. Lighting shall be LED type.
- 3.2.7 **Ventilation:** Furnish and install one (1) new exhaust fan.
- 3.2.8 **Walls:** Retain existing.
- 3.2.9 **Wall Panels:** vandal resistant brushed stainless steel #4 brush finish.
- 3.2.10 **Flooring:** By Contractor or its subcontractor. New VCT tile flooring to be installed. Style to be determined by owner.

3.3 CAR SIGNAL FIXTURES.

- 3.3.1 **Car Operating Panel:** Furnish and install one (2) new car operating stations as described herein. The new car operating station shall be manufactured and installed in accordance with Americans with Disabilities Act (ADA), ANSI Code A17.1, C.A.C. Title 24 and other applicable state and local codes. The new car station shall be constructed of Stainless Steel with a #4 brush finish and vertical grain. The car station shall have the following integrally mounted components:
 - a. All buttons and operating devices to be vandal resistant type. Basis of design to be Innovation Industries "Bruiser" or Adams "Survivor Plus" buttons.
 - b. Illuminating, self-canceling floor call buttons one (1) for each landing served. Each button shall be clearly marked with the designation for the floor that the button serves. The buttons shall have black indications on a contrasting white background. The highest call button shall not exceed 54" above finish floor.
 - c. Alarm button. The Alarm button shall illuminate & extinguish when pushed & released.
 - d. Non-Illuminating buttons labeled Door Open, Door Close, Emergency Stop. These buttons shall be grouped at the bottom of the panel at 35" centerline as required by code. The Emergency Stop and Alarm buttons shall have red characters on contrasting white backgrounds. The Door Open and Door Close buttons shall have black indications on a white background.
 - e. Braille indication to the left of and adjacent to each button designating the function and operation of that button.
 - f. Firefighters Service Cabinet with the following devices behind a locked, hinged, door: Key operated 3 position (Off-Hold-On) Fire Service switch with Fire jewel, Door Open, Door Close and Call Cancel buttons with buzzer that shall operate as required by code in the event of a fire. The firefighters cabinet door shall have One (1) signage plate with Fire Emergency Operation instructions mounted on its interior side.
 - g. One (1) Emergency Light unit with battery backup to provide lighting in the interior of the elevator in the event of a loss of power to the elevator light circuit. The emergency light unit shall also be capable of supplying power to the alarm bell.

- h. One (1) programmable ADA compliant hands free speaker phone assembly.
- i. One (1) Capacity Plate indicating the weight, in pounds, that the elevator is rated to safely carry.
- j. One (1) floor passing gong.
- k. One (1) two position key operated switch labeled Inspection.
- l. One (1) three position key operated switch labeled "Light," "Fan," and "Off."
- m. One (1) Inspection key operated switch for Elevator Inspectors use as required by code.
- n. One (1) Independent Service key operated switch which will allow the elevator to be removed from automatic service and placed on manual operation from inside the elevator.
- o. Additional key or toggle switches as required to match the existing function of any key or toggle switches.
- p. Smoked plastic 6" X 6" lens for future card reader installation.
- q. All illumination of buttons shall be energy efficient LED type. Incandescent is not acceptable.

3.3.2 Car Position Indicator: Furnish and install one (1) new car position indicator in each elevator. The new car position indicators shall be the digital type and shall be mounted in the car operating panel.

3.3.3 Car Direction Lanterns: Furnish and install new car direction lanterns on the car entrance jambs. Illumination of the car direction arrows shall be energy efficient LED type. Basis of design for car direction lantern to be vandal resistant design. Incandescent lighting is not acceptable.

3.4 HALL SIGNAL FIXTURES.

3.4.1 Hall Call Stations: Furnish and install new surface mounted hall stations, one (1) at each landing. Each hall station shall be manufactured of stainless steel with a vertical grain and a #4 brush finish. The new hall stations shall have some combination of the following components:

- a. Illuminating up and/or down buttons.
- b. Fire emergency recall switch at the designated landing.
- c. Fire Service Operating signage as required by ANSI Code.
- d. Fire Service Indicator
- e. Surface-mount design to facilitate easy installation in existing buildings.
- f. All fixtures will be mounted to meet ADA height requirements.
- g. Basis of design for Hall Station buttons to be either Innovation Industries "Bruiser" or Adams "Survivor Plus" vandal resistant design.

3.4.2 Hall Access Stations: New Access key switches shall be installed either in the hall stations or in a separate fixture adjacent to the jamb at the top and bottom landings. The Hall Access key switches are for inspectors use when inspecting the elevator.

3.4.3 Jamb Braille: Install new jamb braille plates at each landing.

3.5 CONTROL & DRIVE SYSTEMS.

3.5.1 Microprocessor Control System: Furnish and install a new non-proprietary microprocessor based control and drive systems. The new microprocessor control system shall be mounted in a fully enclosed cabinet. The cabinet shall utilize hinged doors to provide access to all control system components. The controller shall utilize an internally mounted fan and filter to provide a continuous flow of air to ventilate the control system. The new control system shall be capable of operating in a climate with an ambient air temperature between 70 degrees Fahrenheit and 110 degrees Fahrenheit. The new microprocessor control system shall be manufactured and installed in compliance with ANSI Code A17.1 "Safety Code For Elevators and Escalators" and California Uniform Building Code Title 8. The new microprocessor controller will utilize separate car and machine room microprocessors which shall communicate with each other via serial link communications. Additional microprocessors required for other subsystems may be used but shall be designed to function using serial communications links as described above. The new microprocessor control system shall be designed to continuously scan and analyze all car functions including status of all inputs and outputs, direction of travel, position of car, status of doors, and speed of car. The motion control system shall utilize closed loop feedback to provide the microprocessor with a continuous indication of car speed and direction. The motion control system shall continuously compare the actual car speed to the demand velocity programmed in the microprocessor to insure fastest possible speed profile. Any deviations shall be self corrected to assure a stable ride. Demand velocity shall be based on the position of the car in the hoistway relative to the destination floor and shall be programmed to provide the highest possible rate of acceleration and deceleration up to and including application of the brake, without discomfort, regardless of direction of travel or load in the car. The new microprocessor controller shall utilize isolated inputs and outputs to protect boards against short circuit damage. The microprocessor controller shall be designed to accommodate changes in the building configuration via replacement of software. All adjustments to operational parameters are to be made via a portable laptop type service tool or an on board diagnostic monitor and programming touchpad.

Control systems that utilize proprietary SIMM chips, or require connection to an offsite portal to enable or validate the tool operation are not acceptable.

3.5.2 Drive System and Control: The elevator control system shall have a Variable Voltage Variable Frequency

A.C. (Alternating Current) non-regenerative drive mounted integrally in the controller. The drive shall be utilized to control the acceleration, deceleration, leveling speed, releveling speed, and full speed operation the elevator based on inputs received from the microprocessor based control system. **This controller shall be able to recognize phase loss and take appropriate action so as not to damage the AC motor or controller.**

3.5.3 Microprocessor Dispatch System: Furnish and install a new microprocessor based dispatch system which shall be incorporated integrally into the control cabinets of the new controller. The new microprocessor dispatcher shall be mounted in a fully enclosed cabinet. The cabinet shall utilize front and rear doors to provide access to all control system components. The cabinet shall have an internally mounted fan and filter to provide a continuous flow of air to ventilate the control system. The new dispatch system shall be capable of operating in a climate with an ambient air temperature between 70 degrees Fahrenheit and 110 degrees Fahrenheit. The new microprocessor control system shall be manufactured and installed in compliance with ANSI Code A17.1 "Safety Code For Elevators and Escalators" and California Uniform Building Code Title 24. The new microprocessor dispatcher and car controllers shall communicate with each other via serial link communications. The new microprocessor based dispatcher shall continuously scan and analyze all car and hall calls, car positions, car direction of travel and car status to provide the fastest possible response to hall calls. The new dispatcher shall be provided with a modem for remote monitoring. Telephone line to the modem to be supplied by the contractor. The microprocessor dispatcher shall analyze and monitor the following parameters when assigning hall calls to the system:

- a. Longest existing hall call at floors
- b. Status of elevator (in or out of service)
- c. Status of motor generator (if equipped with motor generator drive)
- d. Direction of travel of each elevator
- e. Position of each elevator
- f. Status of car doors (opening, closing, etc.)
- g. Existing car calls in individual cars
- h. Existing hall calls already assigned
- i. Coincident car calls
- j. System status (Up peak, Down peak, etc.)

3.5.4 Diagnostics: The controller shall have an integrally mounted or separate machine room monitor display which shall be used to review all faults, parameters, and settings. The monitor shall be controlled by some means of interface tool (laptop, desktop, handheld tool) to access menus, tables, and diagnostics. In addition, the interface tool shall also be used to adjust parameters and settings in the control system. The interface tool shall be left at the job and shall become the property of the County.

3.5.5 Automatic Self Leveling: The elevator shall be provided with a self-leveling feature that will automatically bring the car to the floor landings. This self-leveling feature will, within its zone, be entirely automatic and independent of the operating device and shall correct for over travel or under travel and rope stretch.

3.5.6 Landing Control System: Provide a solid state landing control system in the hoistway that shall constantly communicate the elevator position within the hoistway with the machine room microprocessor controller. The landing control system shall utilize a stainless steel tape or hoistway mounted encoder that shall be linked to a positive position unit to provide all required inputs to the elevator microprocessor.

3.5.7 Approved Manufacturers: Elevator control systems are to be manufactured by one of the following manufacturers. Substitutions **MAY** be allowed as long as they have a **PROVEN** track record in hydroelectric elevator applications. Manufacturers that furnish the basis for design are as follows.

- a. Computerized Elevator Controls – SWIFT Futura w/Serial Link configuration
- b. Motion Control Engineering – iControl w/Serial Link configuration
- c. Elevator Controls Corp. – V900-AC w/"E-Z Link" Serial Communication OR Pixel

The new control system shall be configured to accept future installation of the manufacturers remote monitoring and interactive tools as follows:

- a. Computerized Elevator Controls – RemonG2
- b. Motion Control Engineering – imonitor & iReport
- c. Elevator Controls Corp. – Interact

3.6 DOORS & ENTRANCES.

Retain existing doors and entrances. Modify as required to accommodate any new accessories or control equipment installed.

3.7 DOOR OPERATION.

3.7.1 Door Operator: Furnish and install two (2) new door operators and related equipment as described herein, on each elevator to provide smooth, reliable door operation. The new door operators shall open and close the elevator doors. The door control shall be a digital closed loop system incorporating a motor, encoder, and car top control box, and all required linkages and related devices. The closed loop circuit shall provide constant

feedback on the position and velocity of the elevator doors to the car top control box. The motor torque shall be constantly adjusted by the car top control box to maintain the correct door speed based on its position and load. Door movements will be electrically cushioned at both limits of travel. Doors will automatically open when the car arrives at a landing and will automatically close after an adjustable time interval or when the car is dispatched to another landing.

Furnish and install the following:

- a. One (1) new digital closed loop door operator assembly including linkages, drive motor, and drive arms.
- b. One (1) new car door track and hangers.
- c. One (1) new clutch and door restrictor assembly as required by code.
- d. One (1), at each landing, new hoistway interlock assemblies including pick-up roller assemblies, pick up rods, interlock box and contacts. The new interlocks shall include fire rated wire as required by ANSI/ASME Code A17.1 1996 edition and shall be fully code compliant with CAC Title 8.

Clean and degrease the hoistway door tracks, rebuild and replace the hoistway door hanger rollers.

3.7.2 **Approved Manufacturers:**

- a. G.A.L. – MOVFR
- b. Elevator Solutions – Closed Loop HPM

3.8 GOVERNORS & SAFETIES.

3.8.1 Governor: New governor shall be installed in place of the existing governor. The new governor shall include overspeed switches and operation as mandated by code. Install new governor cable.

3.8.2 Car Safety Device: Retain the existing car safety. Inspect same for correct operation and integrity of components. Lubricate pivot points and hinges.

3.9 MACHINES & MOTORS.

3.9.1 Hoist Machine: The existing geared traction machines will be cleaned, checked, painted and reused. Bearing oil reservoirs will be flushed, cleaned, and new oil provided. Drive sheaves will be cleaned and checked for proper traction. Brakes will be cleaned, worn parts replaced, lubricated and adjusted for proper operation. All work will be in accordance with original manufacturer's specifications.

3.9.2 Hoist Motor: Furnish and install one (2) new Alternating Current hoist motor manufactured and designed for use in elevator applications. The new hoist motor shall be designed for use in Variable Voltage Variable Frequency applications. The new motor shall utilize sealed roller bearings to insure quiet operation and long life.

3.10 PIT EQUIPMENT.

3.10.1 Limit Switches and Hoistway Operating Devices: Furnish and install guide rail mounted hoistway limit switches at the terminal landings as required to accommodate the new elevator controller. The limit switches shall mechanically signal the elevator control system that the elevator is at a terminal landing and, if the elevator has traveled too far past the floor. In the event that the elevator over travels by an excessive amount the terminal limit switch shall disconnect power from the elevator and apply the brake.

3.9.2 Pit Switch: Furnish and install an Emergency Stop switch in the elevator pit.

3.9.3 Pit Buffers: Retain the existing pit buffers.

Clean the elevator pit and paint pit equipment with a rust preventive paint.

3.10 ROPES, RAILS & COUNTERWEIGHTS.

3.10.1 Guide Rails: Retain the existing guide rails, and counterweights. Check rails for proper alignment to provide smooth operation.

3.10.2 Earthquake Protection: Provide a seismic switch sensing device in the elevator machine room that shall detect movement in the building structure. The seismic switch shall be coupled to the new elevator control system, which will provide earthquake operation.

The system shall slow the elevator to a code compliant speed stop at the next available floor, or if floor heights exceed 36 feet, stop and then proceed in the direction away from the counterweights to the next floor. Circuitry shall be arranged so that the elevators are operable only on car top inspection control until an elevator mechanic has inspected the elevators and determined that they are safe for normal operation.

If installation of counterweight brackets or counterweight spreader brackets is required as part of this work they shall be designed and installed to withstand a horizontal acceleration of .5 G.

Furnish and install anti-sag protection for all counterweight brackets extending the full height of the hoistway. Protect all switch and cam brackets against hoist, compensating, or traveling cables becoming entangled on them.

Furnish and install retainer plates, if required, on the counterweight frame(s) to deter accidental counterweight derailment.

Furnish and install a sensing device for each counterweight that shall detect any displacement in the building structure or the counterweight leaving its guides.

Furnish and install restraining members for motor generators, controller cabinets, governors, machine bed plates, isolation transformers, and other floor mounted devices to resist a .5 G vertical and 1.0 G Horizontal acceleration.

Furnish and install rope retainers to prevent hoist and governor cables from leaving sheave grooves.

3.10.3 Hoist Ropes: Replace existing hoist ropes.

3.10.4 Rope Grippers (Ascending Safety Device): Furnish and install new "rope gripper" on elevator machine. The rope gripper shall function as ascending safety devices to stop the elevator in the event of an uncontrolled upward movement of the elevator.

4.1 ELECTRICAL POWER AND ELECTRICAL SHUNT WORK

4.2 Contractor shall provide all electrical power up-grades to conform with elevator modernization. This includes shunt work and any other power upgrade to the project. This work may be sub-contracted however must be disclosed at time of bid.

5.1 FIRE AND LIFE SAFETY SYSTEMS

5.2 Contractor shall provide all fire system improvements to conform with elevator modernization. The modernization contractor may sub-contract this work out but must be disclosed at time of bid.

(End of section)

GENERAL REQUIREMENTS:

- 1.1. Identification – Stanislaus County requires all contractor and/or subcontractor personnel working on Stanislaus County’s premises to wear uniforms with company identification supplied by the respective employer. Contractor, subcontractors and its employees immediately upon entering Stanislaus county property shall sign in the contractor logbook located at the main security desk and shall sign out at the end of each workday.**
- 1.2. System of communication and emergency numbers - Contractor shall provide and maintain for the duration of the project, a current list of emergency contact numbers for 24-hour emergency response. In case of emergency contractor shall respond immediately upon notification. Contractor shall notify the Stanislaus County’s building maintenance manager or his designee of the emergency.**
- 1.3. Protection of property – During periods of storms or inclement weather contractor shall provide supervisory inspections of the project during regular assigned hours to prevent or minimize possible damage from inclement weather. Contractor shall report any storm damage to the Stanislaus County’s building maintenance manager or his designee immediately.**
- 1.4. Supervisory personnel – Contractor shall supply adequate onsite supervision for the project. The supervisor shall communicate in English orally and in writing with the Stanislaus County’s building maintenance manager or his designee and shall be comprehensively familiar with these specifications.**
- 1.5. Project inspections – Upon request of the Stanislaus County’s building maintenance manager or his designee contractor or his representative shall walk the project to determine compliance with all codes and specifications listed. The Stanislaus County’s building maintenance manager or his designee shall provide a list of corrections to the contractor. Contractor shall make all noted corrections prior to the next scheduled or requested inspection by Stanislaus county.**
- 1.6. Licensing – Contractor shall be licensed by the state of California in all categories necessary to perform work under this contract and in compliance with all state and local governmental agencies.**
- 1.7. Construction schedules - The contractor shall provide to the Stanislaus County’s building maintenance manager or his designee within five (5) days after receiving the "notice to proceed", a construction schedule in the format of a Gantt chart using the computer program format in Microsoft project 4.0 for windows. The contractor shall also provide a compact disk of said chart at the time of submittal of proposed schedule. Any change in the construction schedule will require the contractor to provide additional charts and disk copies of those changes to the Stanislaus County’s building maintenance manager or his designee within two (2) working days.**
- 1.8. Project completion - Contractor shall provide the Stanislaus County’s building maintenance manager or his designee, upon completion of the project, a final written report. This report must include all project notes and corrections, the equipment user’s manual, manufacturer’s warranty documents, specification sheets, parts diagrams, startup procedures, operational guidelines, maintenance schedules and procedures.**

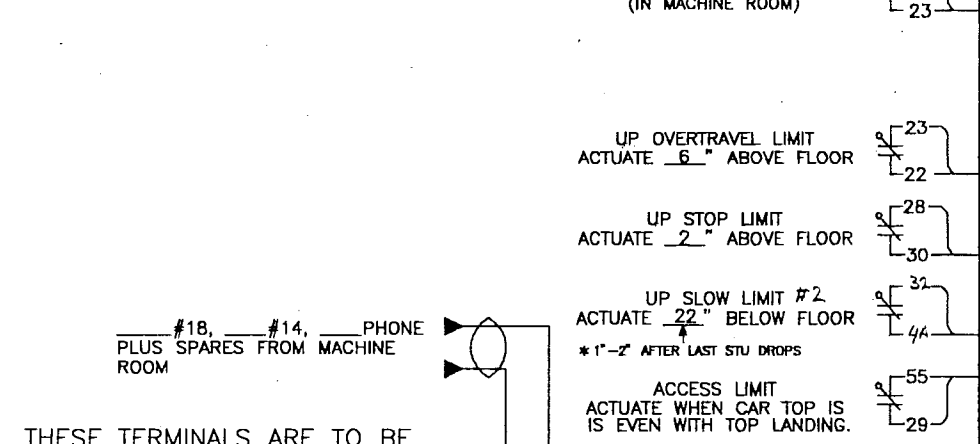

THESE TERMINALS ARE TO BE INCLUDED IN HOISTWAY STRIP FOR CAR#1 AND ARE THE COMMON TERMINALS (HALL CALLS, ETC. -DO NOT CONNECT TRAVELLER)

* LANDING SYSTEM NOTES:

- EFFECTIVE SLOWDOWN DISTANCE APPLIES FROM DROP-OFF POINT OF "STU/STD" VANE TO CENTER OF "DZ".
- USD2/DSD2 MUST OPEN 1-2" AFTER LAST STU/STD DROPS OFF AND REMAIN OPEN FOR CAR RUN-BY PAST TERMINAL FLOOR.

444	50N	64	443
DT**	D2** THRU D3**		
	U1**	U2** THRU U3**	
64B			
3			

NUMBER BOXED IN DOTTED LINES DOES NOT CONNECT TO TRAVELLER.

** - ALSO TO C.O.P.

HOISTWAY JUNCTION BOX TERMINAL STRIP									
3	3R	3X	4	4A	4R	4X	6		
11	12	13	14	14A	15	16	17	19	20
		23	24	25	26	27	28	29	30
		31	32	33	34	35	36		50H
		41			DBC	DOB	PHE	SE	49 50
		51						59	62 63
		71	72			76			
		82	SDA	SUA	FWI	85X			435
	C1	C2	THRU	C3					CT
	P1	P2	THRU	P3					PT
	CO	D03	DO	DC	L2A			50N	
									ND
AC2	#14 BLK	#14 WHT	#14 GRN	AC1	FGEU	FGED		T1	T2

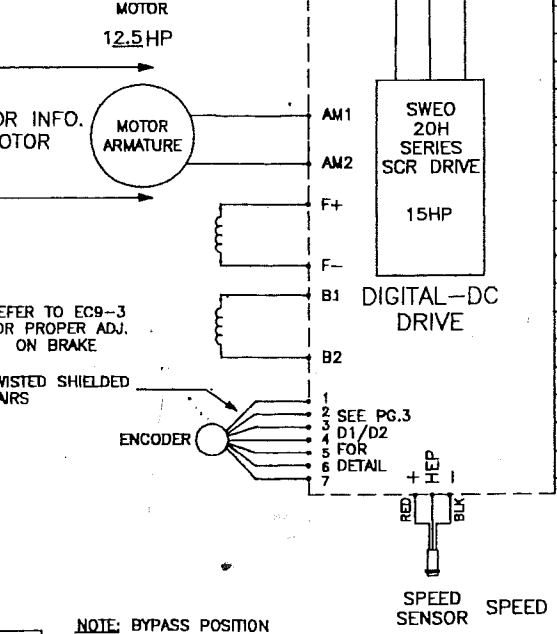
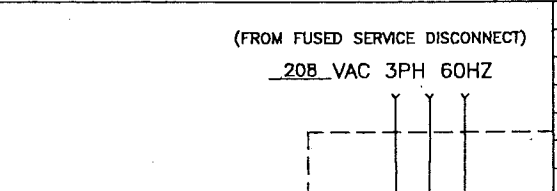
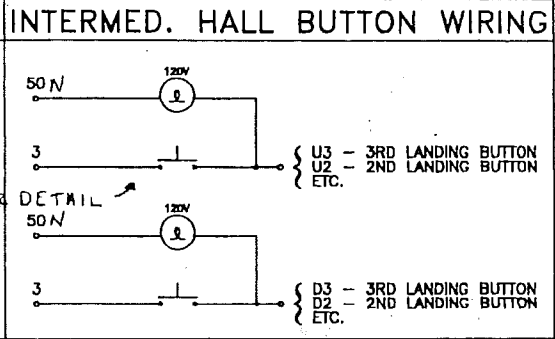
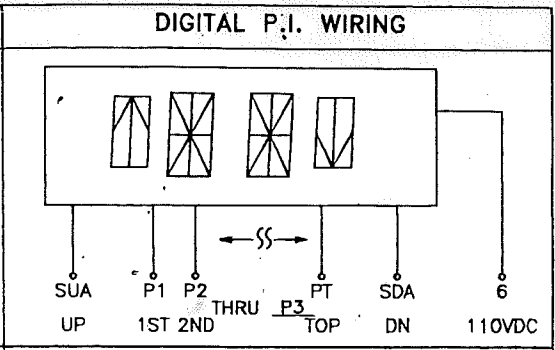
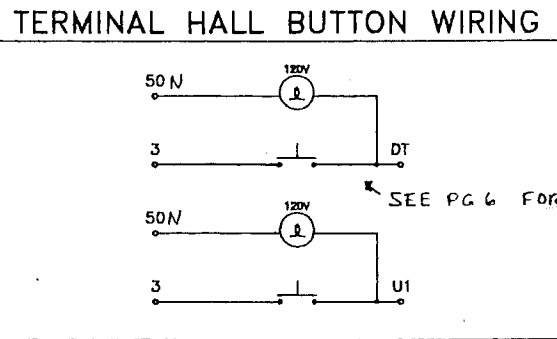
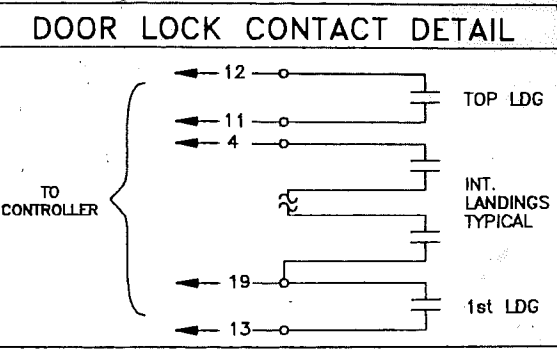
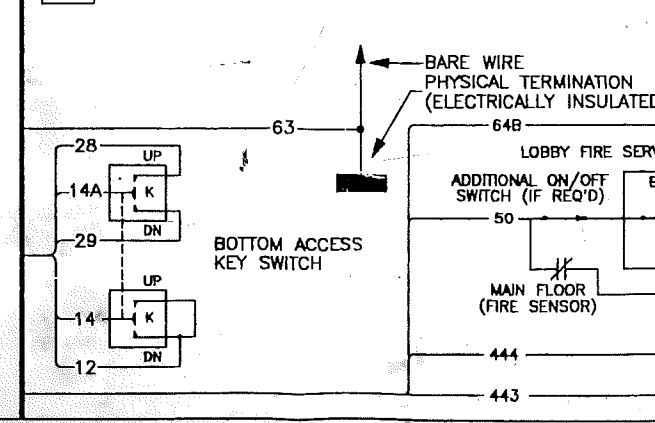
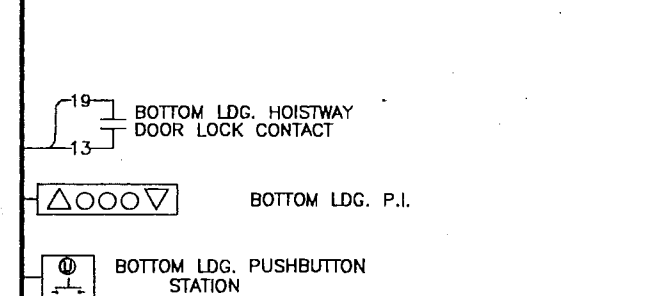
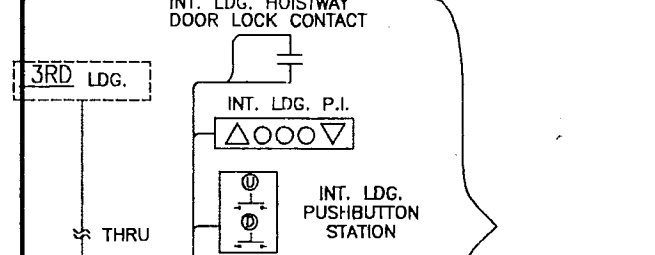
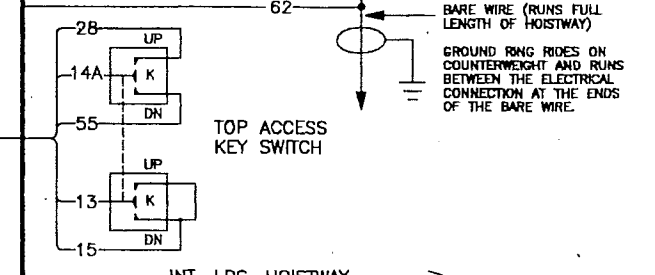
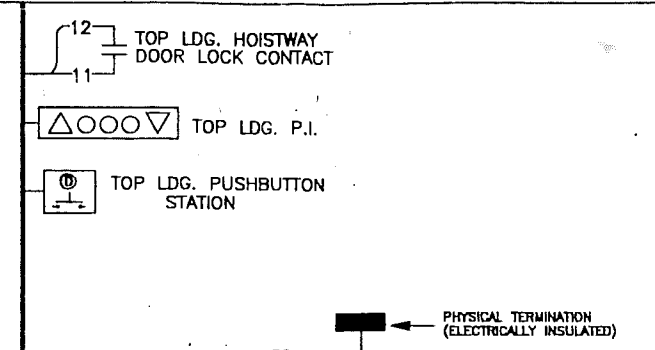
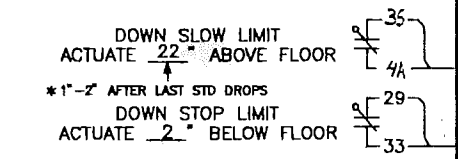
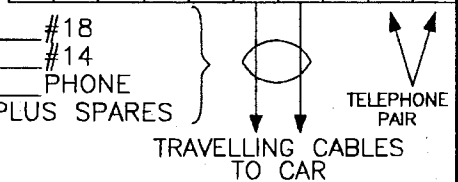

CONTROLLER TERMINAL STRIP (TYPICAL)									
11	12	13	14	15	16	17	19	20	
		23	23A	24	25	26	27	28	29 30
		32	33	35	36	37	38	39	40
		41	42	43	DBC	DOB	PHE	SE	49 50
		51							59
		71	72		65				
					75	76			
					SDA	SUA	FWI	85X	
					THRU				PT
					THRU				P1
					THRU				
						435			
					64				
					443				
					D2	THRU			DT
					111	THRU			
					THRU				
					THRU				
					550	552	THRU		
					651	652	THRU		
					#14 GRN	#14 BLK	#14 WHT	AC2	AC1
					651	650	PG	T1	T2

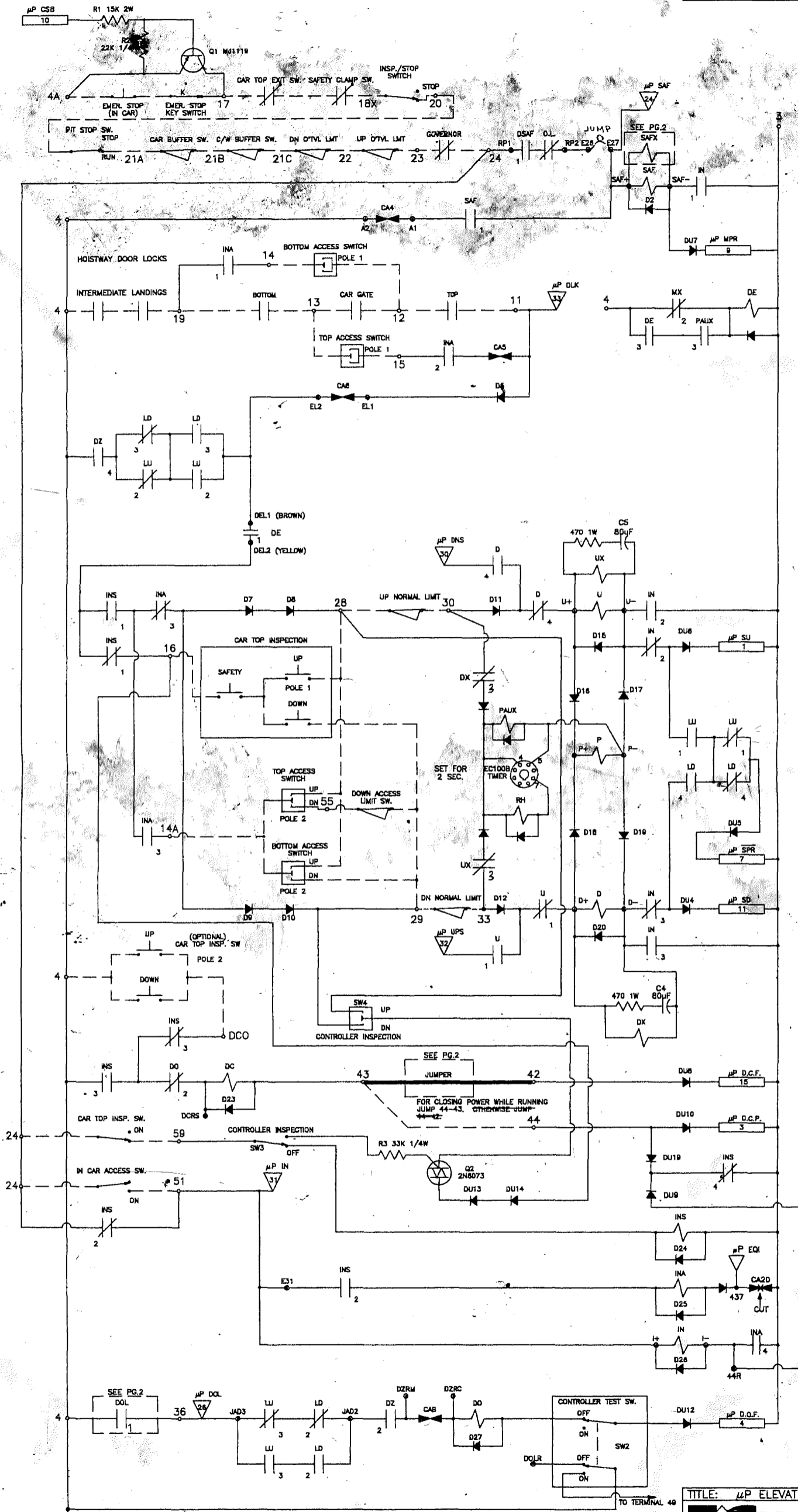

3
4

4
5

NOTE: FOR PRE-OPENING, JUMP JAD 2&3 ON HLS-5B BOARD AND ADJ. SW'S ON CAR TOP TO PREVENT PRE-OPENING OUTSIDE OF ±3" FROM FLOOR LEVEL.

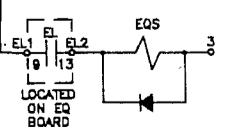

TITLE: MP ELEVATOR CONTROLLER		PAGE 4 OF 9 PAGES
		B/FILE: SAFT.DWG
3025 LeGrande Blvd., Sacramento, CA 95833 (916) 428-1700-701 (916) 428-1728		FILE: J1599_4.DWG
JOB: MODESTO JAIL		
CUSTOMER: KEYSTONE ELEVATOR		
DWN BY: M.D.LORD	DATE: 2/23/95	
CHK BY:	DATE:	
ENGR: MDL	DATE: 3/13/95	
JOB #: 95-1599	DRAWING #:	951599EC9-4

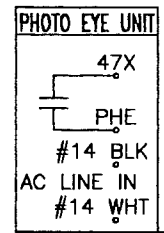
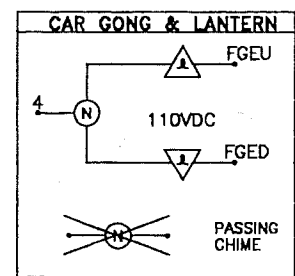
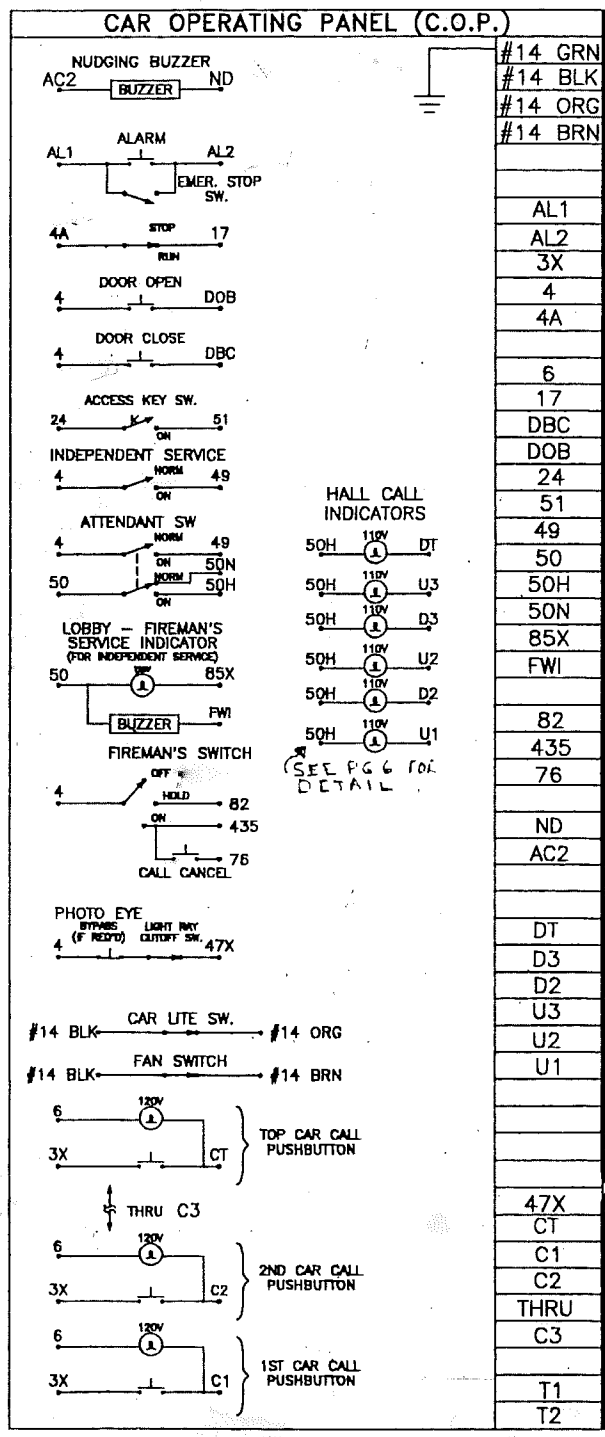
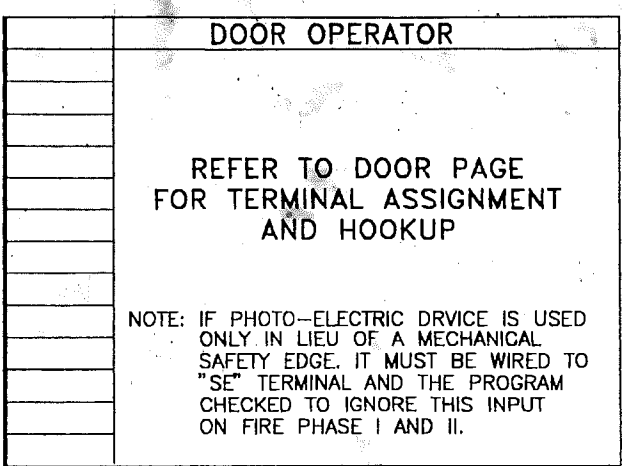
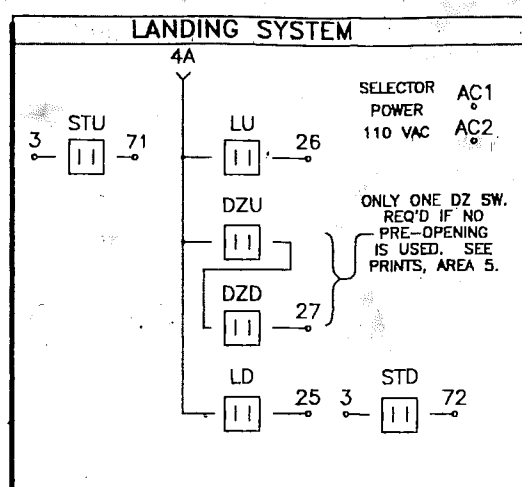
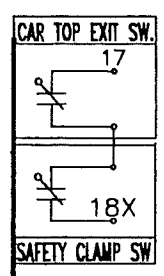
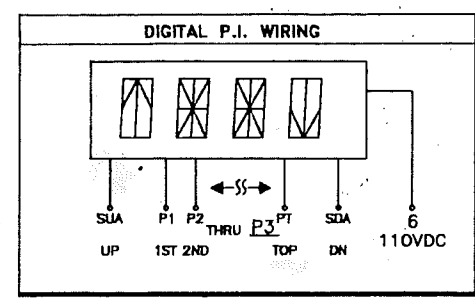

CAR JUNCTION BOX TERMINAL STRIP

3	3R	3X	4	4A	4R	4X	6		
		12	13			16	17	18X	20
				24	25	26	27	28	29
								50N	50H
41				DBC	DOB	PHE	SE	49	50
51		47X						59	
71	72				76				
	82	SDA	SUA	FWI	85X				435
C1	C2	THRU	C3	CT					
P1	P2	THRU	P3	PT					ND
CO	DO	DC	L2A	D03					
D2	D3	DT	U1	U2	U3				
AC2	#14 BLK	#14 WHT	#14 GRN	AC1	FGEU	FGED	T1	T2	

NUMBER BOXED IN DOTTED LINES DOES NOT CONNECT TO TRAVELLER.

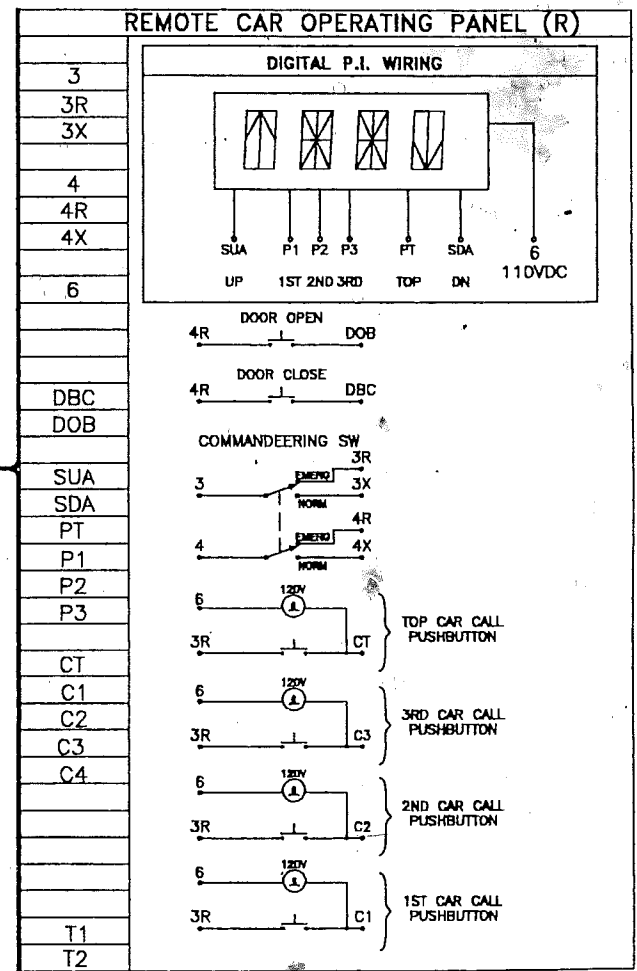
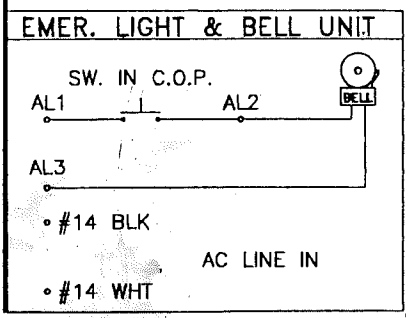
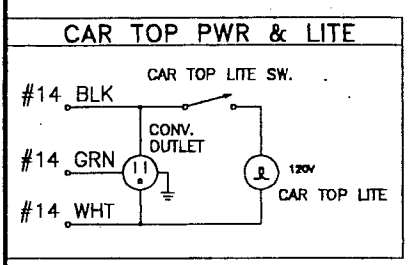
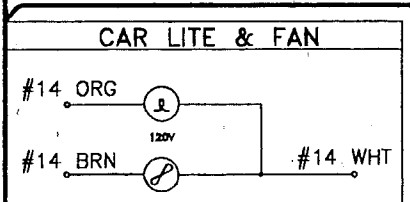
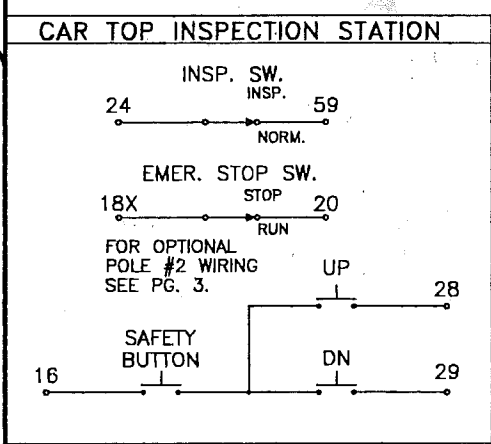
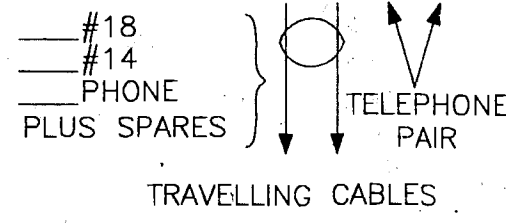

LOGIC CONTACTORS

SYMBOL	NOMENCLATURE	RELAY TYPE	CON. AREA	N.O. H.C.	1	2	3	4	5
IN	INSPECTION/ACCESS	1	5	3	4	4	4	7	
INS	INSPECTION	1	5	4	5	4	4	5	
INA	ACCESS TRANSFER	1	5	3	3	4	4	5	
LU	LEVEL UP	1	6	4	3	5	6	6	
LD	LEVEL DOWN	1	6	6	5	3	3	4	
DZ	DOOR ZONE	1	6	D2	5			3	
H	HIGH SPEED	1	7	D2		7		6	
U	UP PILOT	1	4	4	7			D2	
D	DOWN PILOT	1	4	D2	7	7	7	3	
DC	DOOR CLOSE	1	4	2				D2	
DO	DOOR OPEN	1	5	2	4				
SAF	SAFETY	1	3	3	4			D2	
P	POWER POTENTIAL	1	4		D2			D3	
MX	MOTOR AUX RELAY	4	D3		3	D2		D2	
M	MOTOR CONTACTOR	21	D3	D1	D1		D1	D1	
RUN	RUN RELAY	22	D2	D3	D3	D2			
DSAF	DRIVE SAFETY	19	D2	3	D2				
PAUX	POTENTIAL NO TIME	7	4	D3	D2	3			
UX	UP AUX	7	3		D3		4		
DX	DOWN AUX	7	4		D3		4		
RH	BREAK HOLDING	7	4	D3					
LU2	LEVEL UP (AUX)	1	6	D2		D2			
LD2	LEVEL DN. (AUX)	1	6	D2		D2			
DE	DIRECTION ENABLE	1	3	3		3			
PI	PI-LOBBY PILOT	1	12	12					
EMER	EMERGENCY PILOT	1	12	12					
E	EARTHQUAKE	12	A1	A1	A1				
EB	EARTHQUAKE BOTTOM	12	A1	A1	A1				
EL	EARTHQUAKE LATCH	13	A1	A1	5(A1)				
ET	EARTHQUAKE TOP	12	A1	A1	A1				
EQS	EARTHQUAKE SPEED	1	5	D2	D2				
FRSX	FIRE SERVICE BYPASS RELAY	1	12	12	12		12		

NOTE: SEE DOOR PAGE FOR DOOR RELAY LIST.

SCHEMATIC SYMBOLS

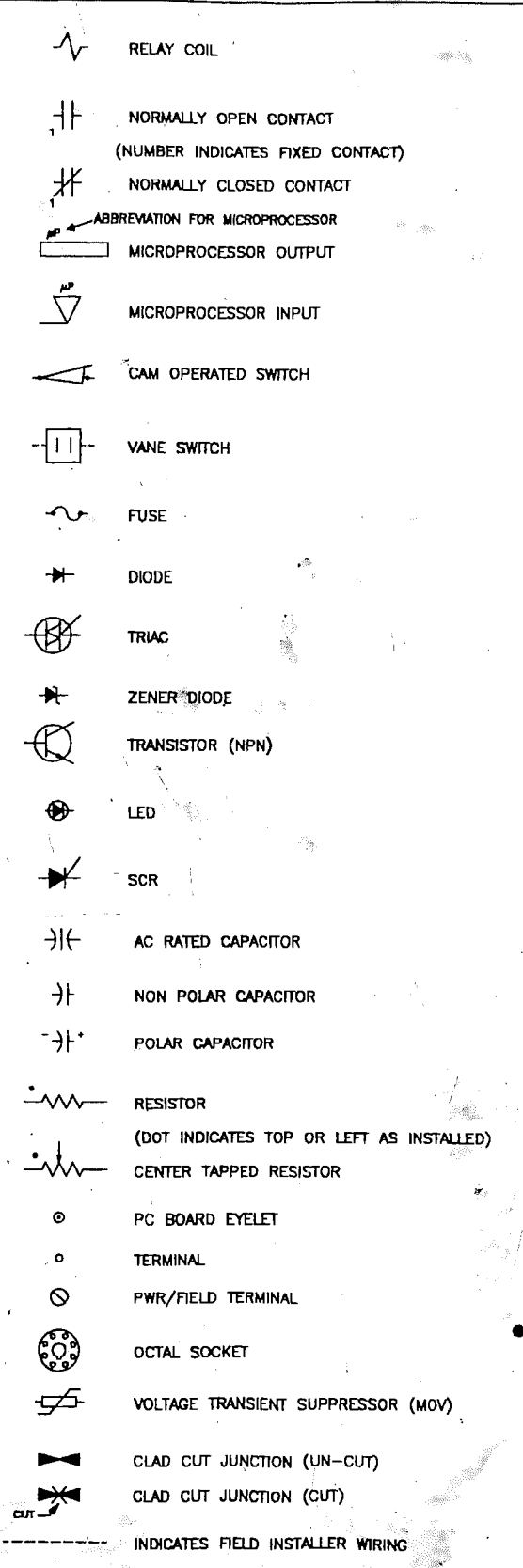

RELAY TYPES:

- KHU17D11N110 4PDT 110VDC
- TRN/D-0 311 2PDT 110VAC/DC
- C-H FREEDOM SERIES STARTER
- KHU17A11N120 4PDT 120VAC
- PM17DY110 4PDT 110VDC
- PRD11DHO-110 2PDT 110VDC
- KUP-14D15-110 3PDT 110VDC
- KUP-14A15-120 3PDT 120VAC
- PM17AY120 4PDT 120VAC
- DS2-M-DC48 2PDT 48VDC
- DS2-ML-DC48 2PDT 48VDC(L)
- DS2-M-DC12 2PDT 12VDC
- DS2-ML-DC12 2PDT 12VDC(L)
- PRD11AHO-120 2PDT 120VAC
- PRD11AYO-120 2PDT 120VAC
- PRD11DYO-110 2PDT 110VDC
- KHU17D11N12 4PDT 12VDC
- KUP-14A35-240 3PDT 240VAC
- KHU17A11N24 4PDT 24VDC
- REVERSE PHASE RELAY
- MITSUBISHI TYPE DU-A CONTACTOR
- KUP-14D15-24 3PDT 24VDC

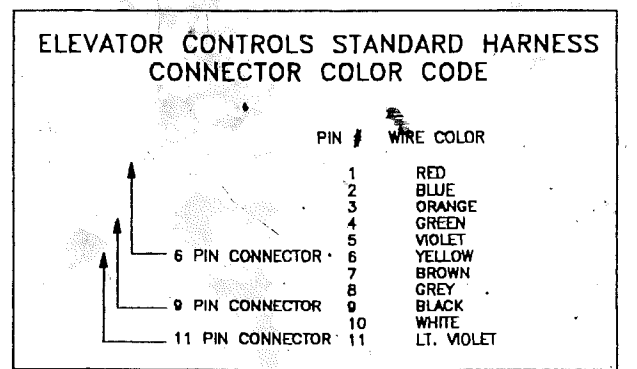
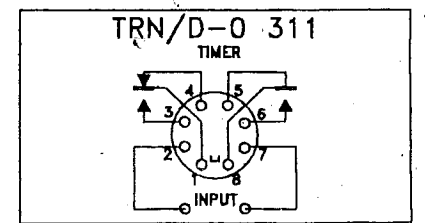
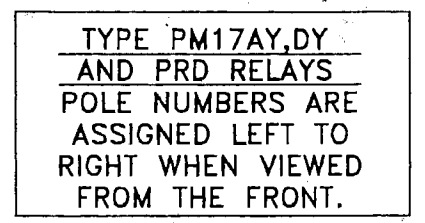
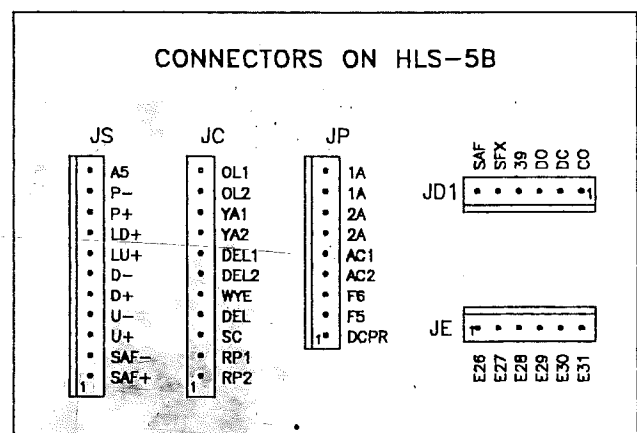
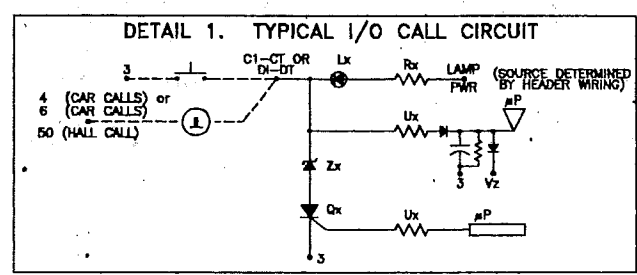
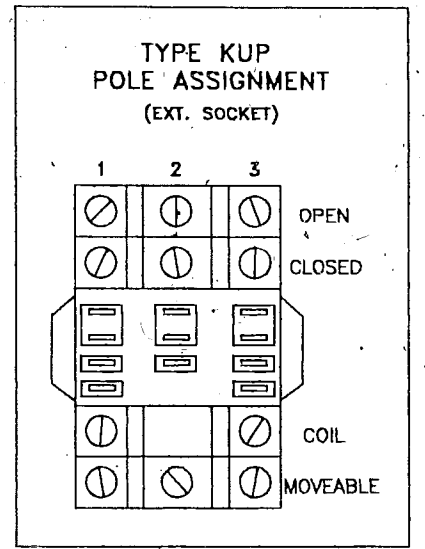
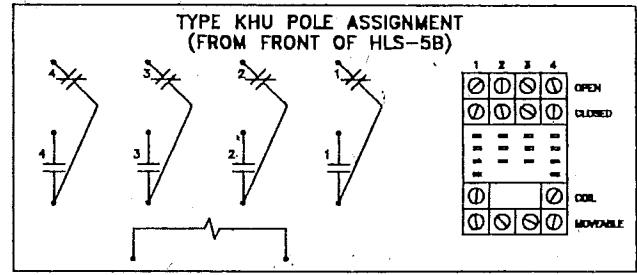

SWEO DC DIGITAL

TITLE: μ P ELEVATOR CONTROLLER

ELEVATOR CONTROLS PAGE 7 OF 9 PAGES

B/FILE: COVRDCD.DWG FILE: J1599_7.DWG

JOB: MODESTO JAIL

CUSTOMER: KEYSTONE ELEVATOR

DWN BY: M.D. LORD DATE: 1/30/95

CHK BY: DATE:

ENGR: MDL DATE: 3/14/95

JOB #: 95-1599 DRAWING #: 951599EC9-7

(916) 428-1708

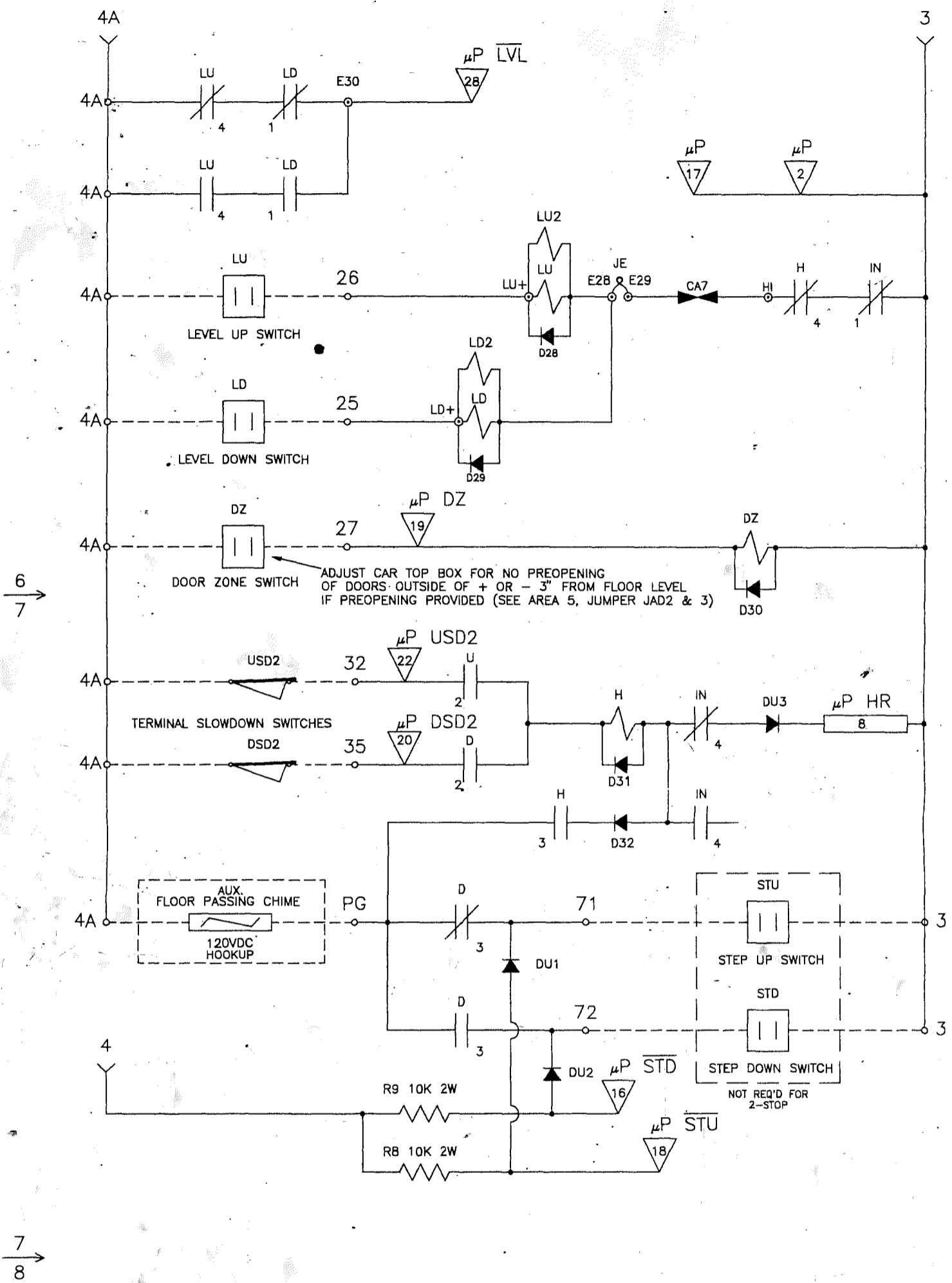

TITLE: LANDING	
 ELEVATOR CONTROLS <small>3535 LaGrande Blvd., Sacramento, CA 95823</small> <small>(916) 428-1728-1744 (916) 428-1728</small>	PAGE 5 OF 9 PAGES
	B/FILE: LDG3.DWG FILE: J1599_5.DWG
JOB: MODESTO JAIL	
CONTRACTOR: KEYSTONE ELEVATOR	
DWN BY: M.D. LORD	DATE: 11/15/94
CHK BY:	DATE:
ENGR: MDL	DATE: 3/13/95
JOB #: 95-1599	DRAWING #: 951599EC9-5

CAR WIRING

MAC PMSSC DOOR OPERATOR

4	EC #	MAC #
12	DO3	DO3
13*	L2A	L2A
L2A	CO	L1A
CO	DO	DO10
DO	DC	DO7
DC	41	DO4
DO3		NUDGING
41	4	
SE	SE	SAFETY EDGE
	12	
	13*	CAR DOOR CONTACT

* - 11 IF NO ACCESS OTHERWISE 13.

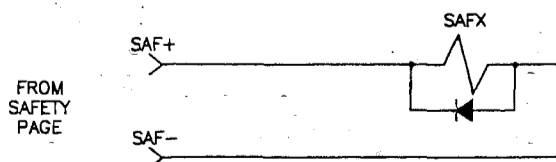
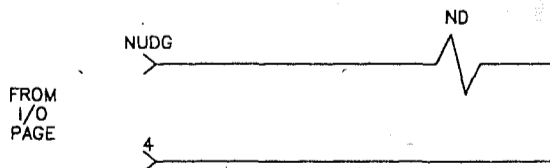
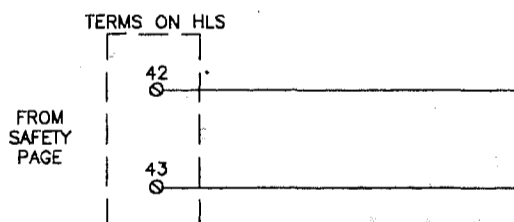
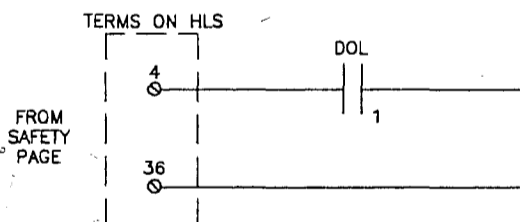
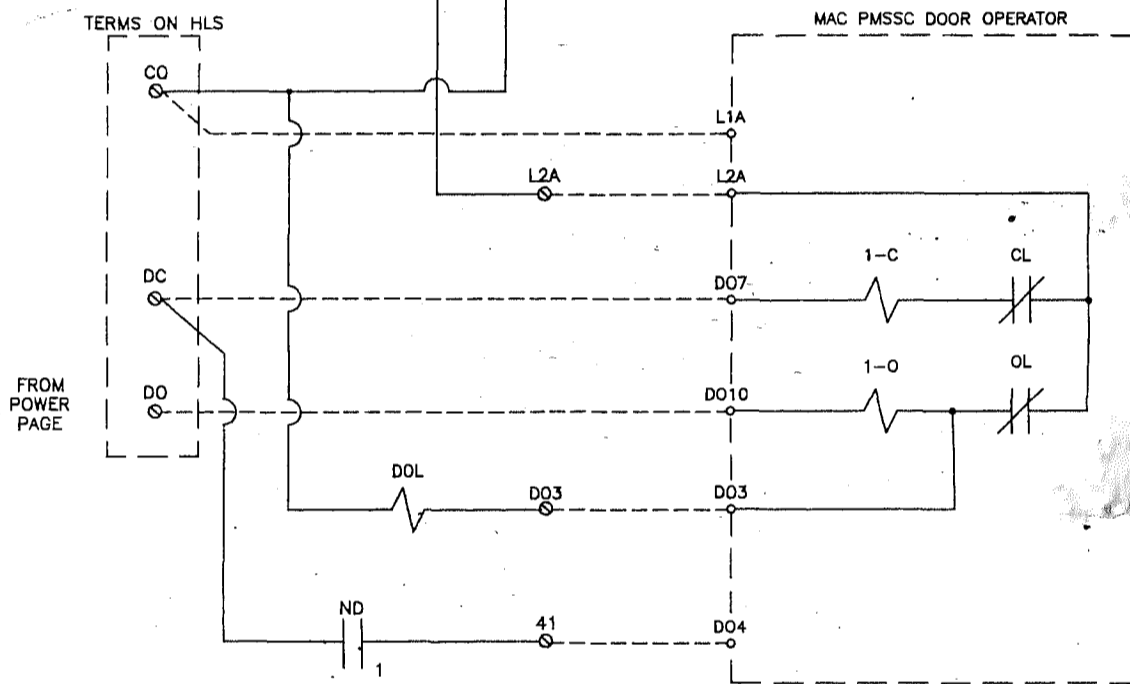
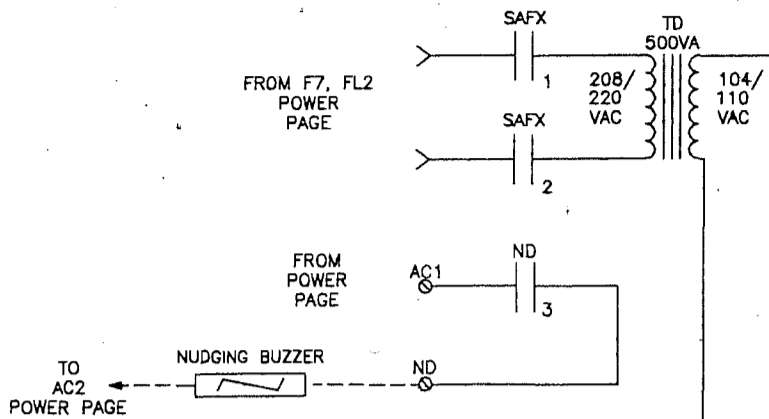

D1
D2

D2
D3

REV. 3/28/95 REC: AS BLT.

SYMBOL	NOMENCLATURE	RELAY TYPE	RELAY AREA	N.O. 1	2	3	4
SAFX	SAFETY AUX	7	D3	D1	D1	2	
ND	NUDGING	7	D3	D2		D1	
DOL	DOOR OPEN LIMIT	1	D2	D2			

NOTE: REFER TO THE CONTACT & SYMBOLS PAGE FOR RELAY TYPE DESCRIPTION.

REV.	DATE
0	9/17/93
1	12/2/93
2	8/30/94

TITLE: MAC-PMSSC MODULAR DOOR CONTROLLER

	ELEVATOR CONTROLS	PAGE 2 OF 9 PAGES
	3825 LeGrande Blvd., Sacramento, CA 95823 (916) 428-1700-442 (916) 428-1700	B/FILE: DMMACP.DWG FILE: J1599_2.DWG
JOB: MODESTO JAIL		
CUSTOMER: KEYSTONE ELEVATOR		
DWN BY: M.D. LORD	DATE: 8/30/94	
CHK BY:	DATE:	
ENGR: MDL	DATE: 3/13/95	
JOB #: 95-1599	DRAWING #: 951599EC9-2	

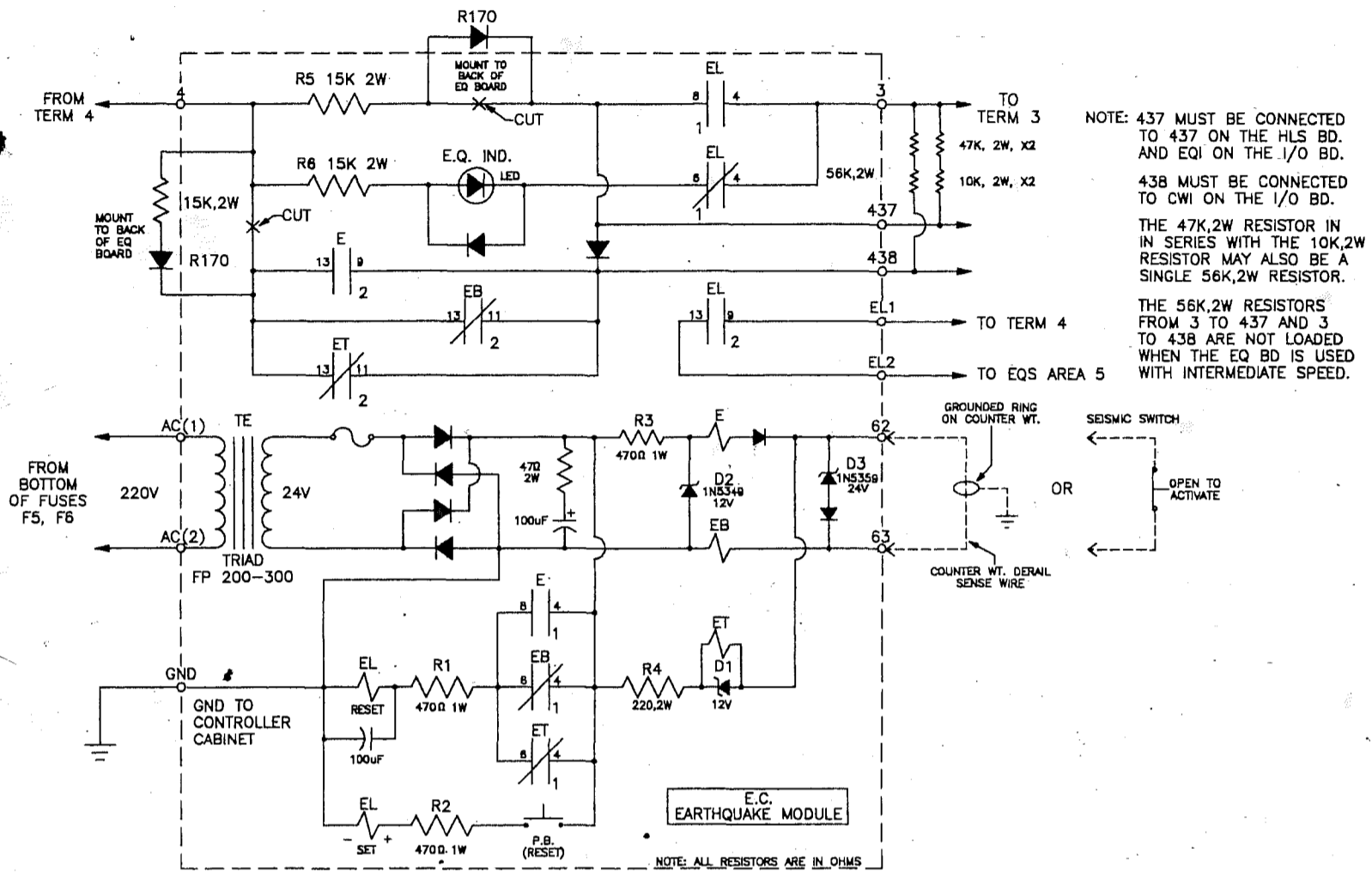

A1
A2

(916-428-1708)

TITLE: μ P ELEVATOR CONTROLLER	
 ELEVATOR CONTROLS <small>3035 LaGrande Blvd., Sacramento, CA 95823 (916) 428-1708-FAX (916) 428-1728</small>	PAGE 5B OF 9 PAGES
	B:/FILE:EQ-LSSM.DWG FILE: J1599_5B.DWG
JOB: MODESTO JAIL	
CUSTOMER: KEYSTONE ELEVATOR	
DWN BY: M.D. LORD	DATE: 12/7/94
CHK BY:	DATE:
ENGR: MDL	DATE: 3/13/95
JOB #: 95-1599	DRAWING #: 951599EC9-5B

208 VAC LINE IN

NOTE: FL1,FL2,FL3,F7,F8 TYPE MDA,
ALL OTHER FUSES TYPE AGC.

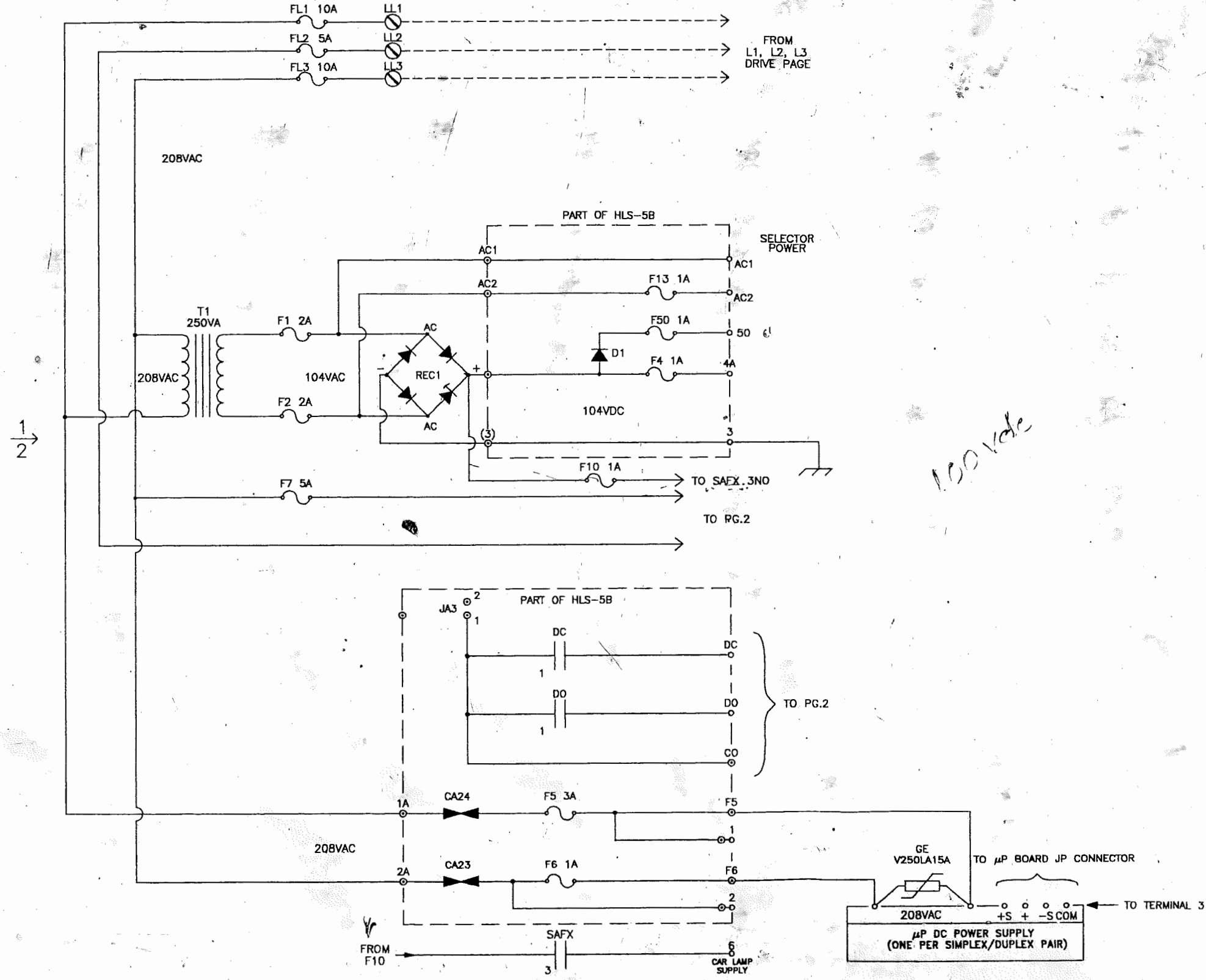

TITLE: μ P ELEVATOR CONTROLLER	
	PAGE 1 OF 9 PAGES
	B/FILE: PWR200.DWG FILE: J1599_1.DWG
JOB: MODESTO JAIL	
CUSTOMER: KEYSTONE ELEVATOR	
DWN BY: M.D. LORD	DATE: 8/18/94
CHK BY:	DATE:
ENGR: MDL	DATE: 3/13/95
JOB #: 95-1599	DRAWING #: 951599EC9-1

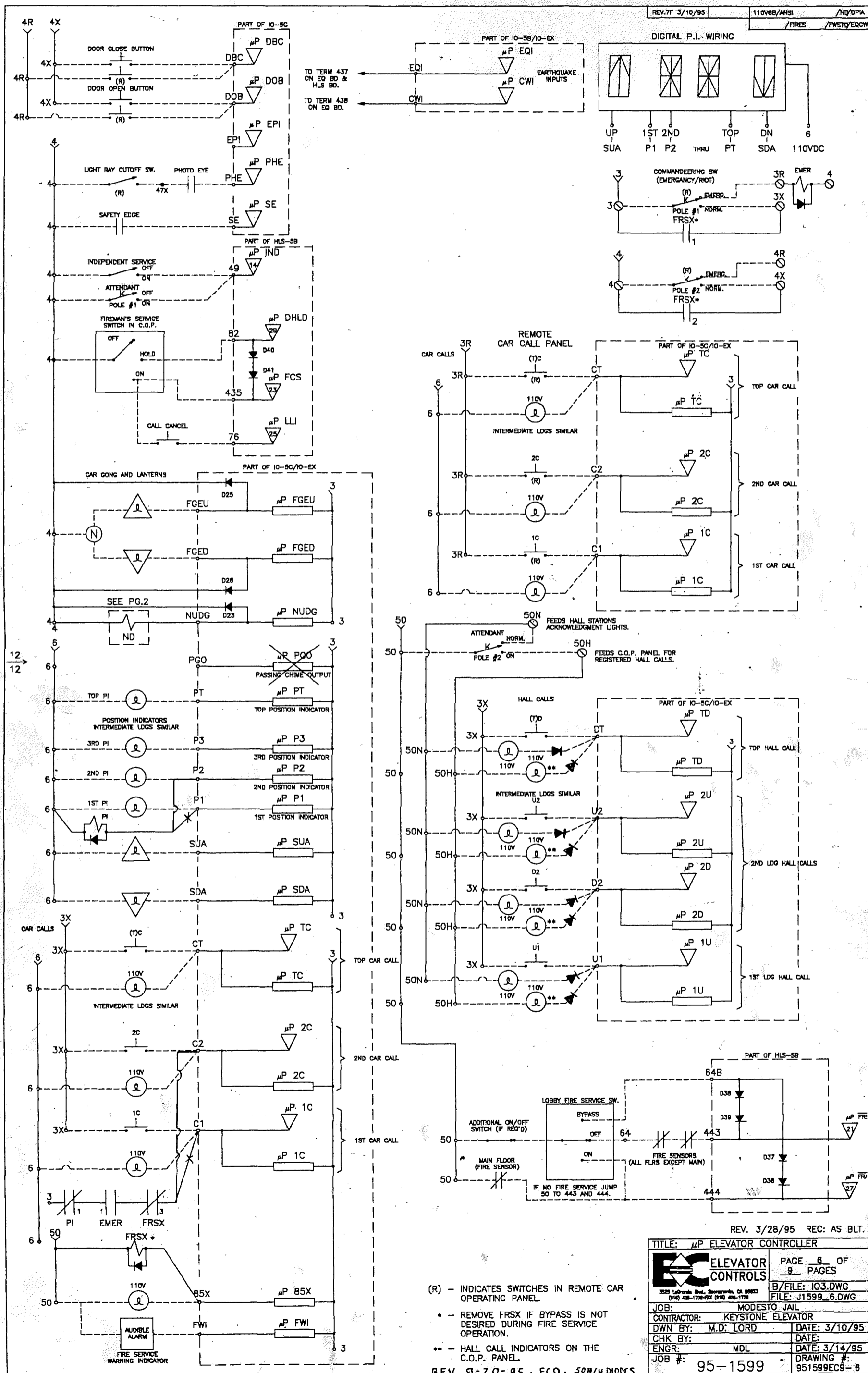

(R) - INDICATES SWITCHES IN REMOTE CAR OPERATING PANEL

* - REMOVE FRSX IF BYPASS IS NOT DESIRED DURING FIRE SERVICE OPERATION.

** - HALL CALL INDICATORS ON THE C.O.P. PANEL.

REV. 3/28/95 REC: AS BLT.

TITLE: μP ELEVATOR CONTROLLER		PAGE 8 OF 9 PAGES	
ELEVATOR CONTROLS		B/FILE: 103.DWG	
3025 Lyndale Blvd., Sacramento, CA 95823 (916) 438-1728/928 (916) 438-1729		FILE: J1599_6.DWG	
JOB: MODESTO JAIL		CONTRACTOR: KEYSTONE ELEVATOR	
DWN BY: M.D. LORD		DATE: 3/10/95	
CHK BY:		DATE:	
ENGR: MDL		DATE: 3/14/95	
JOB #: 95-1599		DRAWING #: 951599EC9-8	

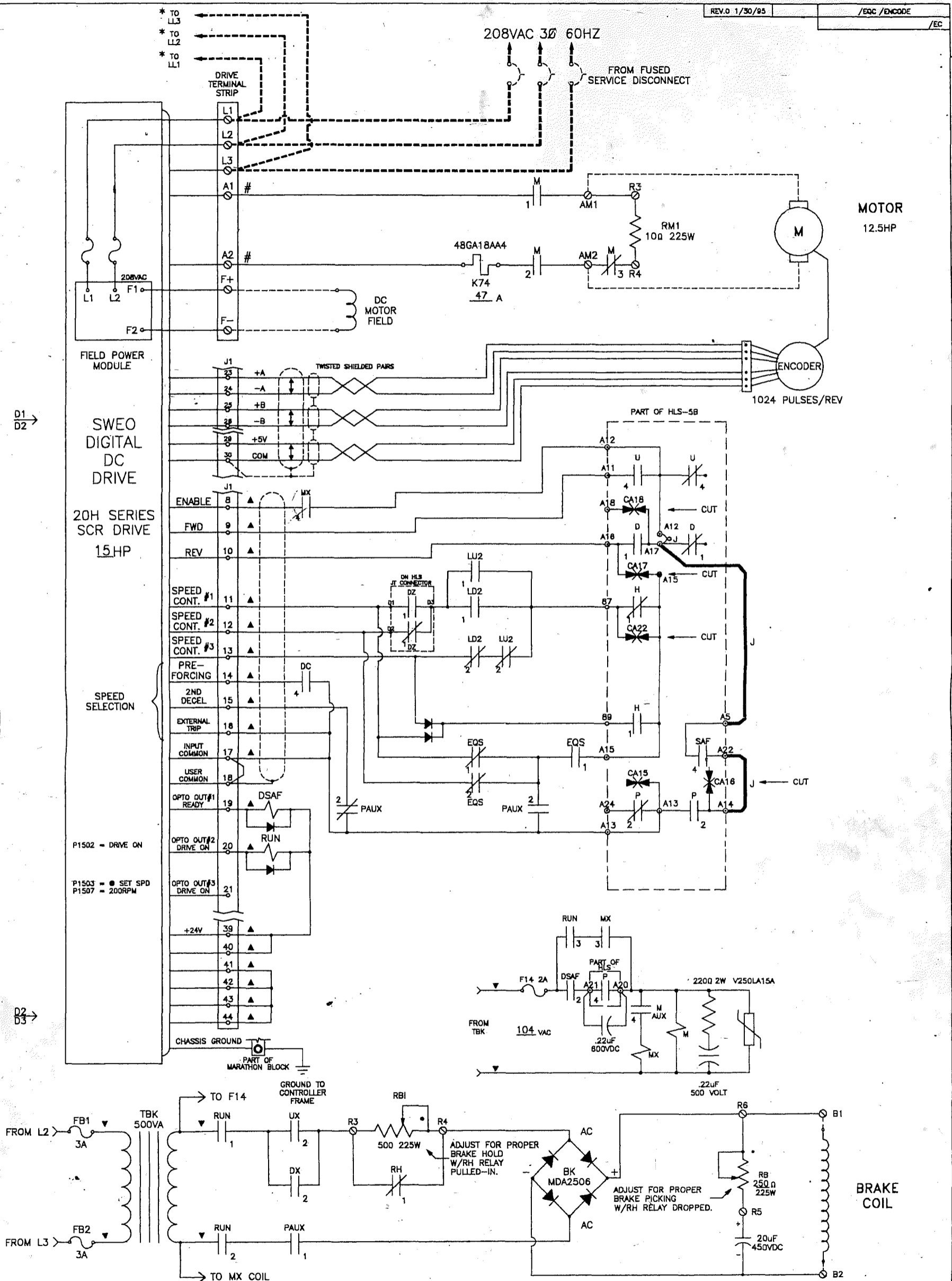

D1
D2 →

D2
D3 →

FIELD DATA

HOIST MOTOR		MOTOR FIELD	
LINE VOLTAGE	208	V. FORCING	125
ARM. LOOP VOLTS	125	V. RUNNING	115
● TOP SPEED	125	V. STANDING	75
M.F. RESISTANCE	94.6 Ω	BRAKE	
HP	12.5	RESISTANCE	750 Ω
FULL LOAD AMPS	47	V. PICKING	125
CAR SPEED	100 FPM	V. HOLDING	110

NOTE: THE ABOVE VALUES ARE BASED IN ORIGINAL DATA SUBMITTED TO ELEVATOR CONTROLS.

START	J1-11	J1-12	J1-13	FUNCTION	F.P.M.	SPD	VALUE
0	OPEN	OPEN	OPEN	1: P1001	SPD		
8	CLOSED	OPEN	OPEN	2: P1002	L1		
15	OPEN	CLOSED	OPEN	3: P1003	L2		
40	CLOSED	CLOSED	OPEN	4: P1004	+EQS		
40	OPEN	OPEN	CLOSED	5: P1005	HL		
*100	CLOSED	OPEN	CLOSED	6: P1008	+H		
*150	OPEN	CLOSED	CLOSED	7: P1007			
*75	CLOSED	CLOSED	CLOSED	8: P1008	+HIL		

↑ VALUE IN FPM TO CONVERT TO RPM FOR PROGRAMMING

MOTOR RATED RPM X DESIRED SPEED FPM

SPD PRESS WHEN USED, SET VALUE SHOWN IN 1/2 CONTRACT SPEED, WHEN OVER 8 LINES * USED ONLY IF RELAY IS PROVIDED OF SAME NAME, OTHERWISE SET TO ZERO

* INDICATES #14AWG
 ▼ INDICATES #18AWG
 ▲ INDICATES #22AWG
 NOTE: ALL RESISTORS ARE IN OHMS.

REV. 3/28/95 REC: AS BLT.

TITLE: SWEO DIGITAL DC DRIVE

ELEVATOR CONTROLS

3025 LeGrande Blvd., Sacramento, CA 95823
 (916) 438-1700 FAX (916) 438-1728

MODесто JAIL
 CUSTOMER: KEYSTONE ELEVATOR
 DWN BY: M.D. LORD DATE: 1/30/95
 CHK BY: DATE:
 ENGR: MDL DATE: 3/14/95
 JOB #: 95-1599 DRAWING #: 951599EC9-3

PAGE 3 OF 9 PAGES
 B/FILE: SWEO DCD.DWG
 FILE: J1599_3.DWG

KEYSTONE ELEVATOR

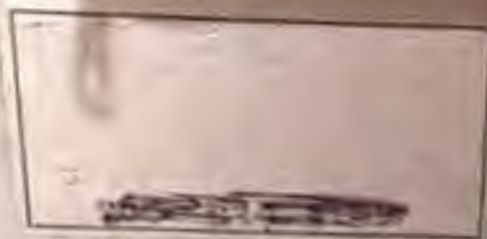

ELEVATOR CONTROLS CORP.

SACRAMENTO CALIFORNIA

CONTROLLER

MODEL 4-250 JOB NO. 41-1000

SERIAL 4001 HP 1/2

VOLTAGE 200 PHASE 3

TYPE 3-1/2" 100-1000 1/2" 100-1000

SHORT CIRCUIT WITHSTAND

1916 428-1708











Original

****COMPLETE & RETURN THIS PAGE****

FORM OF BID

STANISLAUS COUNTY GSA PURCHASING DIVISION

BID NAME: ELEVATOR MODERNIZATION AT MEN'S JAIL
BID NO.: 17-22-BD

ITEM NO.	ITEM	UNIT OF MEASURE	ESTIMATED QUANTITY	ITEM PRICE (IN FIGURES)	TOTAL (IN FIGURES)
ELEVATOR MODERNIZATION (State ID 030125)					
1	Labor	LUMP SUM		\$ 43,777.75	\$ 43,777.75
	Materials	LUMP SUM		\$ 56,541.50	\$ 56,541.50
	Overhead & Profit	LUMP SUM	1	\$ 10,821.75	\$ 10,821.75

PROJECT TOTAL \$ 111,141.00

Prompt Payment Discount

Cash discount of _____% for payment within _____ calendar days, which will be computed from the date delivery is made and accepted by the County, or the date a proper invoice is received, **whichever is later**. Discount offered with payment terms of less than (20) calendar days will not be considered for award purposes. If no discount is shown, then it shall be assumed that none is offered and that the terms are **Net 30 days**.

Payment and Invoicing

Payment for services rendered and accepted will be made on a monthly basis, in arrears, after receipt of a proper detailed invoice approved by County-authorized representative. All invoices must be submitted in duplicate to facilitate payment.

The undersigned Bidder has examined the site and all of the documents, plans, and specifications, and shall perform all work and provide all labor, equipment, and materials for the completion and operation of the project for which this bid is made, all as set forth in the specifications provided by County, at bid amounts as stated above. The undersigned Bidder further agrees as follows:

1. Within ten (10) calendar days from the date the Notice of Acceptance of Bid is issued, shall execute the Contract and furnish to Stanislaus County GSA Purchasing (Purchasing) satisfactory insurance and contract bonds guaranteeing the faithful performance of the work and General Conditions thereto.
2. Begin work on the date specified in the Notice to Proceed letter and prosecute said work in such a manner as to complete it within **FORTY-FIVE (45) Working Days**

The work shall be so scheduled that existing facilities shall not be disrupted, but shall remain in continuous operation on present schedules.

Accompanying this bid is Bidder's security issued in the form of a bond, a cashier check, or a certified check. Refer to the section of this document titled "GENERAL CONDITIONS AND INSTRUCTIONS TO BIDDER" for additional information about bonding requirements.

Name of Bidder: ELEVATOR INDUSTRIES INC.

Business Address: 110 MAIN AVE. Telephone: 916-921-1495

City, State, Zip Code: SACRAMENTO CA. 95838

License #: 982957 License Expiration Date: 7-31-17

Classification: C11 DIR Registration #: 1000009613

Dated: 4-19-17 Fax: 916-921-1496 Email: GUYB@ELEVATOR-INDUSTRIES.COM

By: _____ (Signature)

Name: GUY BUCKMAN, GENERAL MANAGER (Printed) _____ (Title)

Note: If incorporated, President, Secretary or Treasurer should sign as such (if partnership, by all partners thereto).

****COMPLETE & RETURN THIS PAGE****

ADDENDA ACKNOWLEDGEMENT

**BID NAME: ELEVATOR MODERNIZATION AT MEN'S JAIL
BID NO.: 17-22-BD**

Bidder shall complete the below and return with the FORM OF BID:

Addendum No. _____ Dated _____ Date Received _____ Initials _____
Addendum No. _____ Dated _____ Date Received _____ Initials _____
Addendum No. _____ Dated _____ Date Received _____ Initials _____
Addendum No. _____ Dated _____ Date Received _____ Initials _____
Addendum No. _____ Dated _____ Date Received _____ Initials _____
Addendum No. _____ Dated _____ Date Received _____ Initials _____

Bidder's Name (Printed): ELEVATOR INDUSTRIES INC., GUY BUCKMAN
Bidder's Signature: 
Bidder's Title: GENERAL MANAGER

BOND REQUIREMENTS *

Bid Security required	YES	Amount <u>\$ 10% of the Project Price</u>
Performance bond required	YES	Amount <u>\$ 100%</u>
Payment bond required	YES	Amount <u>\$ 100%</u>

*See item 3 under General Terms and Conditions for specific security/bonding requirements. If required, only the successful Bidder shall submit a performance and payment bond as described in the General Terms and Conditions of this Bid.

****COMPLETE & RETURN THIS PAGE****

SUBCONTRACTOR LIST

**BID NAME: ELEVATOR MODERNIZATION AT MEN'S JAIL
BID NO.: 17-22-BD**

Each bid shall have listed therein the name and address of each subcontractor to whom Bidder proposes to subcontract portions of the work in an amount in excess of half of one percent (.5%) of the total bid, or \$10,000, whichever is greater. This is in accordance with the Subletting and Subcontracting Fair Practices Act, commencing with Section 4100 of the Public Contract Code. Bidder's attention is invited to other provisions of said Act related to the imposition of penalties for failure to observe its provisions by using unauthorized subcontractors or by making unauthorized substitutions.

NOTE: A contractor or subcontractor shall not be qualified to bid on, or be listed in a bid proposal, subject to the requirements of Section 4104 of the Public Contract Code, or engage in the performance of any contract for public work, as defined in this Section, unless currently registered and qualified to perform public work pursuant to Section 1725.5 of the Labor Code. It is not a violation of this Section for an unregistered contractor to submit a bid that is authorized by Section 7029.1 of the Business and Professions Code or by Section 10164 or 20103.5 of the Public Contract Code, provided the contractor is registered to perform public work pursuant to Section 1725.5 of the Labor Code at the time the contract is awarded.

	<u>SUBCONTRACTOR TYPE</u>	<u>LICENSE NO.</u>	<u>NAME & ADDRESS OF SUBCONTRACTOR</u>	<u>DIR #</u>
1.	NONE			
2.				
3.				
4.				
5.				
6.				
7.				
8.				
9.				
10.				
11.				
12.				
13.				
14.				
15.				
16.				
17.				
18.				

(Signed) 
Bidder / Prime Contractor

EXHIBIT B

Insurance Requirements for Construction Contracts

Contractor shall procure and maintain for the duration of the contract, and for 3 years thereafter, insurance against claims for injuries to persons or damages to property which may arise from or in connection with the performance of the work hereunder by the Contractor, his agents, representatives, employees, or subcontractors.

MINIMUM SCOPE AND LIMIT OF INSURANCE

Coverage shall be at least as broad as:

1. **Commercial General Liability** (CGL): Insurance Services Office Form CG 00 01 covering CGL on an "occurrence" basis, including products and completed operations, property damage, bodily injury and personal & advertising injury with limits no less than \$5,000,000 per occurrence. If a general aggregate limit applies, either the general aggregate limit shall apply separately to this project/location (ISO CG 25 03 or 25 04) or the general aggregate limit shall be twice the required occurrence limit.
2. **Automobile Liability**: Insurance Services Office Form Number CA 0001 covering Code 1 (any auto), with limits no less than \$5,000,000 per accident for bodily injury and property damage.
3. **Workers' Compensation** insurance as required by the State of California, with Statutory Limits, and Employers' Liability insurance with a limit of no less than \$1,000,000 per accident for bodily injury or disease.
4. **Builder's Risk** (Course of Construction) insurance utilizing an "All Risk" (Special Perils) coverage form, with limits equal to the completed value of the project and no coinsurance penalty provisions.
5. **Surety Bonds** as described below.
6. **Professional Liability** (if Design/Build), with limits no less than \$1,000,000 per occurrence or claim, and \$2,000,000 policy aggregate.
7. **Contractors' Pollution Legal Liability** and/or Asbestos Legal Liability and/or Errors and Omissions (if project involves environmental hazards) with limits no less than \$1,000,000 per occurrence or claim, and \$2,000,000 policy aggregate.

If the contractor maintains broader coverage and/or higher limits than the minimums shown above, the County requires and shall be entitled to the broader coverage and/or higher limits maintained by the contractor. Any available insurance proceeds in excess of the specified minimum limits of insurance and coverage shall be available to the County.

Application of Excess Liability Coverage: Contractors may use a combination of primary, and excess insurance policies which provide coverage as broad as ("follow form" over) the underlying primary policies, to satisfy the Required Insurance provisions.

Other Insurance Provisions

The insurance policies are to contain, or be endorsed to contain, the following provisions:

Additional Insured Status

The County, its officers, officials, employees, agents and volunteers are to be covered as additional insureds on the CGL policy with respect to liability arising out of work or operations performed by or on behalf of the Contractor including materials, parts, or equipment furnished in connection with such work or operations and automobiles owned, leased, hired, or borrowed by or on behalf of the Contractor. General liability coverage can be provided in the form of an endorsement to the Contractor's insurance (at least as broad as ISO Form CG 20 10, CG 11 85 or both CG 20 10, CG 20 26, CG 20 33, or CG 20 38; and CG 20 37 forms if later revisions used).

Primary Coverage

For any claims related to this contract, the Contractor's insurance coverage shall be primary coverage at least as broad as ISO CG 20 01 04 13 as respects the County, its officers, officials, employees, agents and volunteers. Any insurance or self-insurance maintained by the County, its officers, officials, employees, agents or volunteers shall be excess of the Contractor's insurance and shall not contribute with it.

Builder's Risk (Course of Construction) Insurance

Contractor may submit evidence of Builder's Risk insurance in the form of Course of Construction coverage. Such coverage shall name the County as a loss payee as their interest may appear.

If the project does not involve new or major reconstruction, at the option of the County, an Installation Floater may be acceptable. For such projects, a Property Installation Floater shall be obtained that provides for the improvement, remodel, modification, alteration, conversion or adjustment to existing buildings, structures, processes, machinery and equipment. The Property Installation Floater shall provide property damage coverage for any building, structure, machinery or equipment damaged, impaired, broken, or destroyed during the performance of the Work, including during transit, installation, and testing at the County's site.

Reporting

Any failure to comply with reporting provisions of the policies shall not affect coverage provided to the County or its officers, officials, employees, agents or volunteers.

Notice of Cancellation

Each insurance policy required above shall provide that coverage shall not be canceled, except with notice to the County.

Waiver of Subrogation

Contractor hereby agrees to waive rights of subrogation (except for Professional Liability) which any insurer of Contractor may acquire from Contractor by virtue of the payment of any loss. Contractor agrees to obtain any endorsement that may be necessary to affect this waiver of subrogation. The Workers' Compensation policy shall be endorsed with a waiver of subrogation in favor of the County for all work performed by the Contractor, its employees, agents and subcontractors.

Self-Insured Retentions

Self-insured retentions must be declared to and approved by the County. At the option of the County, either: the contractor shall cause the insurer shall reduce or eliminate such self-insured retentions as respects the County, its officers, officials, employees, and volunteers; or the Contractor shall provide a financial guarantee satisfactory to the County guaranteeing payment of losses and related investigations, claim administration, and defense expenses. The policy language shall provide, or be endorsed to provide, that the self-insured retention may be satisfied by either the named insured or County.

Acceptability of Insurers

Insurance is to be placed with California admitted insurers (licensed to do business in California) with a current A.M. Best's rating of no less than A-VII, however, if no California admitted insurance company provides the required insurance, it is acceptable to provide the required insurance through a United States domiciled carrier that meets the required Best's rating and that is listed on the current List of Approved Surplus Line Insurers (LASLI) maintained by the California Department of Insurance.

Claims Made Policies

If any coverage required is written on a claims-made coverage form:

1. The retroactive date must be shown, and this date must be before the execution date of the contract or the beginning of contract work.
2. Insurance must be maintained and evidence of insurance must be provided for at least five (5) years after completion of contract work.
3. If coverage is canceled or non-renewed, and not replaced with another claims-made policy form with a retroactive date prior to the contract effective, or start of work date, the Contractor must purchase extended reporting period coverage for a minimum of five (5) years after completion of contract work.
4. A copy of the claims reporting requirements must be submitted to the County for review.
5. If the services involve lead-based paint or asbestos identification/remediation, the Contractors Pollution Liability policy shall not contain lead-based paint or asbestos exclusions. If the services involve mold identification/remediation, the Contractors Pollution Liability policy shall not contain a mold exclusion, and the definition of Pollution shall include microbial matter, including mold.

Verification of Coverage

Contractor shall furnish the County with original certificates and amendatory endorsements, or copies of the applicable insurance language, effecting coverage required by this contract. All certificates and endorsements are to be received and approved by the County before work commences. However, failure to obtain the required documents prior to the work beginning shall not waive the Contractor's obligation to provide them. The County reserves the right to require complete, certified copies of all required insurance policies, including endorsements, required by these specifications, at any time. We strongly recommend obtaining a copy of the policy declarations and endorsement page (make this a requirement in your Contract) to facilitate verification of coverages and spot any undesirable policy limitations or exclusions.

Subcontractors

Contractor shall require and verify that all subcontractors maintain insurance meeting all the requirements stated herein, and Contractor shall ensure that County is an additional insured on insurance required from subcontractors. For CGL coverage subcontractors shall provide coverage with a format least as broad as CG 20 38 04 13.

Surety Bonds

Contractor shall provide the following Surety Bonds:

1. Bid bond
2. Performance bond
3. Payment bond
4. Maintenance bond

The Payment Bond and the Performance Bond shall be in a sum equal to the contract price. If the Performance Bond provides for a one-year warranty a separate Maintenance Bond is not necessary. If the warranty period specified in the contract is for longer than one year a Maintenance Bond equal to 10% of the contract price is required. Bonds shall be duly executed by a responsible corporate surety, authorized to issue such bonds in the State of California and secured through an authorized agent with an office in California.

Special Risks or Circumstances

County reserves the right to modify these requirements, including limits, based on the nature of the risk, prior experience, insurer, coverage, or other circumstances.

Insurance Limits

The limits of insurance described herein shall not limit the liability of the Contractor and Contractor's officers, employees, agents, representatives or subcontractors. Contractor's obligation to defend, indemnify and hold the County and its officers, officials, employees, agents and volunteers harmless under the provisions of this paragraph is not limited to or restricted by any requirement in the Agreement for Contractor to procure and maintain a policy of insurance.

[SIGNATURES SET FORTH ON THE FOLLOWING PAGE]

APPROVED AS TO INSURANCE CONTENT:

Stanislaus County

Chief Executive Office – Risk Management Division

By: Kevin Watson

Name: Kevin Watson

Title: Liability & Insurance Manager

Date: 11/1/2017